

Introduction

This Amendment No. 6 to the Rule 13e-3 Transaction Statement (“Transaction Statement”) is being filed with the U.S. Securities and Exchange Commission (the “SEC”) pursuant to Section 13(e) of the Securities Exchange Act of 1934, as amended, by (i) Cnova N.V. (“Cnova”); (ii) Casino, Guichard-Perrachon S.A. (“Casino”) and (iii) Companhia Brasileira de Distribuição (“CBD”).

On August 8, 2016, Cnova, Cnova Comércio Eletrônico S.A. (“Cnova Brazil”) and Via Varejo S.A. (“Via Varejo”) entered into a Reorganization Agreement providing for the reorganization of Cnova Brazil within Via Varejo (the “Reorganization”). In connection with the Reorganization, Casino executed a letter agreement pursuant to which Casino agreed to launch tender offers to purchase any and all outstanding ordinary shares of Cnova at a price of \$5.50 per share, subject only to completion of the Reorganization. Further, pursuant to a separate letter agreement, CBD agreed not to tender the Cnova shares it owns into Casino’s potential tender offers nor otherwise transfer its Cnova shares prior to the completion of the tender offers.

On October 31, 2016, the Reorganization was completed.

On December 6, 2016, pursuant to requirements of French law, Casino published a draft *note d’information* (the “French Offer Document”) in connection with the French Offer, and Cnova published a draft *note d’information en réponse* (the “French Response Document”), which includes the response of the Cnova board of directors to the French Offer Document.

Item 15. Additional Information

Item 15(c) is hereby amended and supplemented by adding the following immediately after the final paragraph thereof:

Pursuant to requirements of French law, on December 6, 2016, Casino published a draft *note d’information* (the “French Offer Document”) in connection with its offer (the “French Offer”) to purchase any and all outstanding ordinary shares, nominal value €0.05 per share, of the Company (“Cnova Ordinary Shares”), from holders of Cnova Ordinary Shares not resident in the United States of America (“Non-U.S. Holders”) who are permitted to participate in the French Offer pursuant to local laws and regulations applicable to those Non-U.S. Holders. Also on December 6, 2016, Cnova published a draft *note d’information en réponse* (the “French Response Document”), which includes the response of the Cnova board of directors to the French Offer Document. The French Offer is part of the offer to purchase any and all outstanding Cnova Ordinary Shares that was previously announced by Casino in connection with the reorganization of the Company’s Brazilian subsidiary within Via Varejo S.A., which was completed on October 31, 2016.

Casino will also be making an offer (the “U.S. Offer” and, together with the French Offer, the “Offers”) to purchase any and all outstanding Cnova Ordinary Shares held by persons resident in the United States (“U.S. Holders,” as such term is defined in Rule 14d-1 under the United States Securities Exchange Act of 1934, as amended).

The Offers are expected to commence on December 27, 2016.

Casino will file with the United States Securities and Exchange Commission (the “SEC”) a Tender Offer Statement on Schedule TO and other documents relating to the U.S. Offer upon commencement of the U.S. Offer, which will be available on the SEC’s website at www.sec.gov.

English translations of the French Offer Document and the French Response Document are attached as Exhibits (a)(9) and (a)(10), respectively, to this Transaction Statement and contain additional information about the French Offer.

THIS TRANSACTION STATEMENT AND EXHIBITS (A)(9) AND (A)(10) ATTACHED HERETO ARE NEITHER AN OFFER TO PURCHASE NOR SOLICITATION OF AN OFFER TO SELL SECURITIES. INVESTORS ARE ADVISED TO READ CASINO’S TENDER OFFER STATEMENT IF AND WHEN IT BECOMES AVAILABLE BECAUSE IT WILL CONTAIN IMPORTANT INFORMATION.

The Offers for the Company’s outstanding ordinary shares described in this Transaction Statement and in the exhibits to this filing have not commenced. When the Offers are commenced, Casino will file a tender offer statement on Schedule TO with the SEC, and the Company will timely file a solicitation/recommendation

statement on Schedule 14D-9, with respect to the U.S. Offer. Casino and the Company intend to mail these documents to the shareholders of the Company. The tender offer statement (including the offer to purchase, the related letter of transmittal and other offer documents) and the solicitation/recommendation statement will contain important information that should be read carefully before any decision is made with respect to the tender offer. Those materials, as amended from time to time, will be made available to the Company's shareholders at no expense to them at www.cnova.com. In addition, the tender offer materials and other documents that Casino may file with the SEC will be made available to all shareholders of the Company free of charge at www.groupe-casino.fr. All of those materials (and all other offer documents filed with the SEC) will be available at no charge on the SEC's website: www.sec.gov. Documents may also be obtained from the Company upon written request to the Investor Relations Department, WTC Schiphol Airport, Tower D, 7th Floor, Schiphol Boulevard 273, 1118 BH Schiphol, The Netherlands, telephone number +31 20 795 06 71.

Item 16. Exhibits

Regulation M-A Item 1016

- (a)(1) Cnova N.V. Shareholders' Circular, dated September 15, 2016*
- (a)(2) Supplemental Information Statement Relating to the Reorganization of the Brazilian Activities of Cnova N.V. within Via Varejo S.A.*
- (a)(3) Press release of Cnova N.V., dated September 15, 2016, titled "CNOVA N.V. Publishes Notice of Extraordinary General Meeting of Shareholders" (incorporated herein by reference to Exhibit 99.1 to the Report on Form 6-K of Cnova N.V., filed with the SEC on September 15, 2016)
- (a)(4) Notice of Extraordinary General Meeting of Shareholders of Cnova N.V. (incorporated herein by reference to Exhibit 99.2 to the Report on Form 6-K of Cnova N.V., filed with the SEC on September 15, 2016)
- (a)(5) Form of Proxy Card for Holders of Cnova N.V. Ordinary Shares (incorporated herein by reference to Exhibit 99.4 to the Report on Form 6-K of Cnova N.V., filed with the SEC on September 15, 2016)
- (a)(6) Form of Voting Proxy for Cnova N.V. Special Voting Shares (incorporated herein by reference to Exhibit 99.5 to the Report on Form 6-K of Cnova N.V., filed with the SEC on September 15, 2016)
- (a)(7) Form of Voting Proxy for Certain Registered Shareholders of Cnova N.V. (incorporated herein by reference to Exhibit 99.6 to the Report on Form 6-K of Cnova N.V., filed with the SEC on September 15, 2016)
- (a)(8) Press release of Cnova N.V., dated October 31, 2016, titled "CNOVA N.V. Announces Completion of the Reorganization of its Brazilian Activities within Via Varejo" (incorporated herein by reference to Exhibit 99.1 to the Report on Form 6-K of Cnova N.V., filed with the SEC on October 31, 2016)
- (a)(9) Draft French Offer Document, dated December 6, 2016.
- (a)(10) Draft French Response Document, dated December 6, 2016.
- (b) None.
- (c)(1) Opinion of Eight Advisory France S.A.S., dated August 8, 2016*
- (c)(2) Valuation Report of BNP Paribas Corporate Finance, dated August 8, 2016*
- (c)(3) Valuation Report of Credit Agricole Corporate & Investment Bank and Rothschild & Cie, dated May 9, 2016*
- (c)(4) Report of Messier Maris & Associés, dated May 10, 2016*
- (c)(5) Valuation Report of Banco Santander (Brasil) S.A., dated August 5, 2015*
- (c)(6) Valuation Analysis of Eight Advisory France S.A.S., dated May 11, 2016*
- (c)(7) Valuation Analysis Update of Eight Advisory France S.A.S., dated July 30, 2016*
- (c)(8) Draft Valuation Report of BNP Paribas Corporate Finance, dated March 23 2016*
- (c)(9) Draft Valuation Report of BNP Paribas Corporate Finance, dated April 13, 2016*

- (c)(10) Draft Valuation Report of BNP Paribas Corporate Finance, dated May 10, 2016*
- (c)(11) MOU Indicative Terms Analysis and Synergies Analysis of BNP Paribas Corporate Finance, dated May 10, 2016*
- (c)(12) Draft Valuation Report of BNP Paribas Corporate Finance, dated July 29, 2016*
- (d)(1) Reorganization Agreement by and among Via Varejo S.A., Cnova Comércio Eletrônico S.A. and Cnova N.V., dated August 8, 2016*
- (d)(2) Undertakings Letter from Casino, Guichard-Perrachon to the Transaction Committee of Cnova N.V., dated August 8, 2016 (incorporated herein by reference to Exhibit 99.4 to the Preliminary Communication of Casino, Guichard-Perrachon filed under Cover of Schedule TO-C with the SEC on August 9, 2016)
- (d)(3) Commitment Letter from Casino, Guichard-Perrachon to Companhia Brasileira de Distribuição, dated August 8, 2016*
- (d)(4) Support Letter from Companhia Brasileira de Distribuição to Casino, Guichard-Perrachon, dated August 8, 2016*
- (f) Not Applicable.
- (g) None.

* Previously filed.

[Remainder of this Page Intentionally Left Blank]

SIGNATURE

After due inquiry and to the best of each of the undersigned's knowledge and belief, each of the undersigned certifies that the information set forth in this statement is true, complete and correct.

Dated as of December 6, 2016

CNOVA N.V.

By: /s/ Emmanuel Grenier _____

Name: Emmanuel Grenier

Title: Chief Executive Officer

SIGNATURE

After due inquiry and to the best of each of the undersigned's knowledge and belief, each of the undersigned certifies that the information set forth in this statement is true, complete and correct.

Dated as of December 6, 2016

CASINO, GUICHARD-PERRACHON S.A.

By: /s/ Jean-Charles Naouri _____

Name: Jean-Charles Naouri

Title: Chairman and Chief Executive Officer

SIGNATURE

After due inquiry and to the best of each of the undersigned's knowledge and belief, each of the undersigned certifies that the information set forth in this statement is true, complete and correct.

Dated as of December 6, 2016

COMPANHIA BRASILEIRA DE DISTRIBUIÇÃO

By: /s/ Ronaldo Iabrudi dos Santos Pereira _____

Name: Ronaldo Iabrudi dos Santos Pereira

Title: Chief Executive Officer

COMPANHIA BRASILEIRA DE DISTRIBUIÇÃO

By: /s/ Christophe José Hidalgo _____

Name: /s/ Christophe José Hidalgo

Title: Chief Financial and Investor Relations Officer

*Translation for information purposes only.
In case of discrepancy between the French and the English version, the French version shall prevail.*

DRAFT OFFER DOCUMENT REGARDING THE SIMPLIFIED TENDER OFFER TARGETING THE SHARES OF



INITIATED BY



PRESENTED BY

J.P.Morgan

CASINO, GUICHARD-PERRACHON S.A.

OFFER PRICE: an amount in euros equivalent to U.S. \$ 5.50 per ordinary share

Tendering shareholders will receive an amount in euros per tendered ordinary share equivalent to U.S. \$5.50 per ordinary share, calculated by using the WM/Reuters index spot exchange rate for euros per U.S. dollar at 5:00 p.m. (Paris time) on the business day following the closing of the offer, rounded down to the nearest thousandth euro, provided that the global amount paid under each tender order will be rounded down to the nearest lesser euro cent.

OFFER PERIOD: 22 trading days

The timetable of the offer will be set out by the *Autorité des marchés financiers* (the French Market Authority (“AMF”)) pursuant to the AMF General Regulations



This Offer and this draft offer document are subject to the review of the AMF.

This draft offer document has been prepared and filed with the AMF on December 6, 2016 in accordance with Articles 231-13, 231-16 and 231-18 of the AMF General Regulations. This draft offer document has been prepared by Casino, Guichard-Perrachon and the signatories are responsible for it.

IMPORTANT NOTICE

If, following the completion of the Offers, Casino, Guichard-Perrachon and its group companies own 95% or more of the issued and outstanding ordinary share capital (*geplaatst en uitstaand gewoon kapitaal*) of Cnova, then Casino, Guichard-Perrachon, acting on its own or with its group companies, would have the right, but not the obligation, to initiate a buy-out procedure (*uitkoopprocedure*) in accordance with Article 2:92a or 2:201a of the Dutch Civil Code and/or a takeover buy-out procedure in accordance with Article 2:359c of the Dutch Civil Code.

The shareholder’ attention is drawn to the fact that those who decide to tender their ordinary shares in the Offer will remain exposed to the EUR / U.S. \$ exchange rate fluctuation until the setting of this rate the trading day following the closing of the

Offer around 5:00 pm (Paris time) (see section 3.4), and consequently, the amount in euros they will receive for each ordinary share tendered to the Offer, on the settlement of the Offer, will not be known before that date and in particular, will not be known on the date on which they decide to tender their shares to the Offer.

Casino is also making a concurrent, separate offer to purchase any and all ordinary share held by persons resident in the United States (“**U.S. Holders**”) at a price of U.S. \$5.50 per ordinary share to all holders of Shares resident in the United States of America (the “**U.S. Offer**”). **Holders of Shares resident in the United States may only tender their ordinary share to the U.S. offer.**

This draft offer document is available on the websites of the AMF (www.amf-france.org) and Casino, Guichard-Perrachon S.A. (<http://www.groupe-casino.fr>) and may be obtained free of charge upon request to:

Casino, Guichard-Perrachon S.A.
1, Cours Antoine Guichard – 42000 Saint-Étienne
France

JPMorgan Chase Bank, N.A.
14, Place Vendome - 75001 Paris
France

This draft offer document, which has not yet been approved by the AMF as well as other information relating in particular to the legal, financial and accounting characteristics of Casino, Guichard-Perrachon shall be made available to the public free of charge at the offices of J.P. Morgan, as well as on the web sites of the AMF (www.amf-france.org) and Casino, Guichard-Perrachon (<http://www.groupe-casino.fr>), pursuant to article 231-27 2° of the AMF General Regulations. A press release will be issued pursuant to article 221-3 of the AMF General Regulations in order to inform the public of the manner in which these documents will be made available.

Pursuant to Article 231-28 of the AMF General Regulations, the legal, financial and accounting information concerning Casino, Guichard-Perrachon will be made available to the public no later than on the day preceding the opening of the simplified tender offer.

This Offer and this draft offer document are subject to the review of the AMF

TABLE OF CONTENT

1. PRESENTATION OF THE COMPANY, BACKGROUND AND RATIONALE FOR THE REORGANIZATION AND THE TRANSACTION	5
1.1 CONTEXT OF THE OFFER	5
1.2 COMPLETION OF THE REORGANIZATION	18
1.3 TRANSACTION AGREEMENTS	22
2. PRESENTATION OF THE OFFER	31
2.1 CAPITAL AND VOTING RIGHTS OF CNOVA REPARTITION	31
2.2 INTENTIONS OF THE OFFEROR FOR THE COMING TWELVE MONTHS	33
2.2.1 <i>Strategic rationale and future activity</i>	33
2.2.2 <i>Composition of the Cnova's Board</i>	34
2.2.3 <i>Intentions regarding employment and management</i>	35
2.2.4 <i>Situation of LTI beneficiaries</i>	35
2.2.5 <i>Dividend distribution policy</i>	36
2.2.6 <i>Perspective regarding possible merger</i>	36
2.2.7 <i>Liquidity</i>	36
2.2.8 <i>Squeeze-out (retrait obligatoire)</i>	36
2.2.9 <i>Delisting following a Buy-Out</i>	37
2.2.10 <i>Delisting aside from a Statutory Buy-Out</i>	37
2.3 AGREEMENTS WHICH COULD HAVE A MATERIAL IMPACT ON THE VALUATION OR OUTCOME OF THE OFFER	38
3. TERMS AND FEATURES OF THE OFFER	38
3.1 FEATURES OF THE OFFER	38
3.2 CONDITION TO WHICH THE OFFER IS SUBJECT	40
3.3 NUMBER AND NATURE OF THE SHARES TARGETED BY THE OFFER	40
3.4 TERMS OF THE OFFER	41
3.5 PROVISIONAL TIMETABLE FOR THE OFFER	42
3.6 EXTENSION OF THE OFFER PERIOD	43
3.7 FINANCING OF THE OFFER	43
3.7.1 <i>Expenses of the Offers</i>	43
3.7.2 <i>Cost and financing of the Offers</i>	43
3.8 RESTRICTIONS RELATING TO THE OFFER OUTSIDE FRANCE	43
3.9 TAX REGIME APPLICABLE TO THE OFFER	44
3.9.1 <i>Individual shareholders who are tax residents of France, who hold the shares in their personal portfolio and who do not carry on a trading activity in conditions which are similar to those of a professional trading activity</i>	45
3.9.2 <i>Corporate shareholders subject to French corporation tax</i>	47
3.9.3 <i>Shareholders subject to a different tax regime</i>	47
3.9.4 <i>Registration duties</i>	48
4. VALUATION CRITERIA FOR THE OFFER	49
4.1 METHODOLOGY	49
4.2 SOURCES OF INFORMATION AND ASSUMPTIONS	50
4.2.1 <i>Sources of information</i>	50
4.2.2 <i>Equity value ("EqV") to Firm value ("FV") adjustments</i>	51
4.2.3 <i>Number of Shares</i>	51
4.2.4 <i>Foreign exchange assumptions</i>	52
4.3 VALUATION ASSESSMENT METHODOLOGIES	52
4.3.1 <i>Primary valuation methods</i>	52
4.3.2 <i>Valuation methods used for indicative purposes</i>	53
4.3.3 <i>Disregarded valuation methods</i>	53
4.4 METHODS USED TO ASSESS THE VALUATION	54
4.4.1 <i>Discounted Cash Flows (DCF)</i>	54
4.4.2 <i>Trading multiples</i>	56
4.4.3 <i>Share price evolution</i>	59
4.5 VALUATION SUMMARY	61

5. PERSONS RESPONSIBLE FOR THE OFFER DOCUMENT

62

5.1 FOR THE OFFEROR

62

5.2 FOR THE PRESENTATION OF THE OFFER

62

*Translation for information purposes only.
In case of discrepancy between the French and the English version, the French version shall prevail.*

This Offer and this draft offer document are subject to the review of the AMF

Pursuant to Title III of Book II and more specifically Article 233-1 1° of the AMF General Regulations, Casino, Guichard-Perrachon S.A.^[1], a *société anonyme* with a share capital of 171,319,066.38 euros, having its registered office located at 1, Cours Antoine Guichard – 42000 Saint-Etienne (France), registered to the Register of Commerce and Companies of Saint-Etienne under registration number 554 501 171, whose shares are admitted to trading on the regulated market of Euronext Paris (the “**Offeror**” or “**Casino**”), is making an irrevocable offer to the shareholders of Cnova N.V., a public limited liability company incorporated under the laws of the Netherlands, with as at the date of this draft offer document an aggregate issued and outstanding share capital of 42,670,639.90 euros, having its registered office located Schiphol Boulevard 273, 1118 BH Schiphol, The Netherlands, and registered with the Netherlands Trade Register under number 60776676 (“**Cnova**” or the “**Company**”), whose shares are admitted to trading on the regulated market of Euronext in Paris (“**Euronext Paris**”) under ISIN code NL0010949392, mnemonic “CNV” and on the NASDAQ Global Select Market (“**NASDAQ**”), ticker “CNV,” to purchase any and all of their ordinary shares, each having a nominal value of EUR 0.05 (the ordinary shares of Cnova being referred as to “**Shares**”) on the terms and conditions set forth below, at a price in euros equivalent to U.S. \$5.50 per ordinary share, net to the seller in cash, calculated by using the WM/Reuters index spot exchange rate for euros per U.S. dollar at 5:00 p.m. (Paris time) on the business day following the closing of the offer, rounded down to the nearest thousandth euro; it being specified, that the global amount paid under each tender order will be rounded down to the nearest lesser euro cent^[2] (hereinafter referred to as the “**Offer**,” and, together with Casino’s separate, concurrent offer to purchase Shares in the United States of America from persons resident therein at a price of U.S. \$5.50 per Share, the “**Offers**”).

If, following the completion of the Offers, Casino and its affiliated companies own 95% or more of the issued and outstanding ordinary share capital (*geplaatst en uitstaand gewoon kapitaal*) of Cnova, then Casino, acting on its own or with its affiliated companies, would have the right, but not the obligation, to initiate, within three months following completion of the Offers, a buy-out procedure (*uitkoopprocedure* in accordance with Article 2:92a or 2:201a of the Dutch Civil Code (which is referred to herein as a “**Statutory Buy-Out**”) and/or a takeover buy-out procedure in accordance with Article 2:359c of the Dutch Civil Code (which is referred to herein as a “**Takeover Buy-Out**” and, together with the Statutory Buy-Out, as a “**Buy Out**”) in order to acquire the Shares not tendered in the Offers and not held by Casino and its affiliated companies or Cnova at an equitable price that will be determined by the competent Dutch court.

This fair price per Share will typically be equal to the consideration per Share offered in the Offers (if this price has been considered fair by the independent expert) unless there would be financial, business or other developments or circumstances that would justify a different price (including a reduction resulting from the payment of dividends or a higher price) in accordance with, respectively, Article 2:92a, paragraph 5 or 2:201a, paragraph 5 or Article 2:359c, paragraph 6 of the Dutch Civil Code. Similarly, if, following the completion of the Offers, Casino and its group companies own 95% or more of the issued and outstanding ordinary share capital (*geplaatst en uitstaand gewoon kapitaal*) of Cnova and 95% or more of the voting interests in Cnova, any minority shareholder would have the right, but not the obligation, to institute a court procedure pursuant to Article 2:359d of the Dutch Civil Code to require Casino to purchase its Shares against a fair price to be determined by the competent Dutch court, as described above. A minority shareholder would have to file such claim with the competent Dutch court within three months after the end of the acceptance period of the Offers.

¹ Casino is the ultimate holding company of the Casino group, a food distribution global actor, whose shares are listed on Euronext Paris under the number ISIN FR0000125585, indirectly controlled by Jean-Charles Naouri, who is also Chairman and Chief Executive Officer of Casino.

² This exchange rate is more specifically defined in section 3.4.

*Translation for information purposes only.
In case of discrepancy between the French and the English version, the French version shall prevail.*

This Offer and this draft offer document are subject to the review of the AMF

The Offer is made in the context of the reorganization, completed on October 31, 2016 (the “**Reorganization Date**”) between Cnova Comércio Eletrônico S.A., a Brazilian private corporation (*sociedade anônima*), which is referred to herein as “**Cnova Brazil**” until now subsidiary of Cnova, and Via Varejo S.A., a Brazilian corporation (*sociedade anônima*), which is referred to herein as “**Via Varejo**”, CBD subsidiary as contemplated by the Reorganization Agreement whose main terms are defined in paragraph 1.3 below (the “**Reorganization**” and, together with the Offers, the “**Transactions**”).

Although the Offer is technically open to all holders of Shares, subject to section 3.8, including the RS, (as described hereinafter in section 2.2.4), i.e. 344,507,048 Shares, the Offer will not be accepted by the Offeror and the following subsidiaries under the Offeror’s exclusive control, namely (i) Companhia Brasileira de Distribuição a sociedade anônima organized under the laws of Brazil, headquartered in the City of São Paulo, State of São Paulo, at Avenida Brigadeiro Luiz Antônio, 3142, Brazil, registered with the CNPJ/MF under number 47.508.411/0001-56 (“**CBD**”), which has agreed not to tender the Shares which it directly or indirectly holds into the Offer, and (ii) Almacenes Exito S.A., Almacenes Exito S.A., a company organized under the laws of Colombia, which is headquartered at Envigado, Antioquia, Colombia registered with the Trade Office under number 890900608-9 (“**Exito**”) which has indicated that it does not intend to tender the Shares it directly holds into the Offer. The Offeror undertakes that it will not, and the Offeror will take all necessary measures to enforce its contractual and social rights in order to make sure that CBD and Exito to not, tender the Shares directly or indirectly held by such holders into the Offer. Taking into account the foregoing undertaking, the Offer will, as a practical matter, target only ordinary shares owned (directly and indirectly) by shareholders other than Casino, Exito and CBD.

The Offer does not target the following Cnova securities, which are not Shares:

- 314,940,097 special voting shares owned by a foundation (*stichting*) under Dutch law named Stichting Cnova Special Voting Shares (the “**Voting Foundation**”) described in Section 2.1 below, and which cannot be transferred, under the terms governing the Voting Foundation and the provisions of the special voting shares themselves, to any person other than Cnova; and
- 97,174,855 special voting shares and the 96,790,798 Distribution Preferred Shares acquired by Cnova within the Reorganization and with a view to having them cancelled.

To the knowledge of the Offeror, there is no capital security or any other financial instrument or right which give or may give access, immediately or in the future, to the share capital or voting rights of the Company, except the Shares (including the restricted stock (the “**RS**”)), the special voting shares described in Section 2.1 below, the deferred stock units (the “**DSU**”) described in Section 2.2.4 below and the Distribution Preferred Shares defined below and under cancellation.

The Offer does not target DSUs as they are not currently transferable but targets, if applicable, a maximum number of 172,389 Shares that could be issued to the holders of DSUs governed by the *Sous Plan Qualifié Français* (as defined in section 2.2.4), in case of death of their beneficiary. The Offer also targets all of the RS (which are Shares subject to transfer restrictions as described in section 2.2.4 hereinafter), among which only two-thirds are transferrable during the Offer period. Apart from those Shares and RS, no new shares can be issued pursuant to the DSU and the Omnibus Incentive Plan (as defined below) before November 19, 2018. The terms and conditions for the issuance of Shares under the *Sous Plan Qualifié Français* and the transferability of the RS are described in section 2.2.4 below

*Translation for information purposes only.
In case of discrepancy between the French and the English version, the French version shall prevail.*

This Offer and this draft offer document are subject to the review of the AMF

The Offer concerns a maximum number of 35,742,321 Shares, consisting of (i) the 344,507,048 existing Shares (including the RS), less (ii) the 308,937,116 Shares held by the Offeror and its controlled subsidiaries with which it is acting in concert (meaning CBD and Exito), plus (iii) the 172,389 Shares arising, as the case may be, from the DSU, governed by the “*Sous-Plan Qualifié Français*”.

JPMorgan Chase Bank, N.A. through its Parisian branch (“**J.P. Morgan**”), as the presenting bank for the Offer, acting on behalf of the Offeror, filed this draft offer document with the AMF on December 6, 2016. Pursuant to the provisions of Article 231-13 of the AMF General Regulations, J.P. Morgan guarantees the content and the irrevocable nature of the undertakings given by the Offeror in connection with the Offer.

Casino is also making a concurrent, separate offer to purchase any and all Shares held by persons resident in the United States (“**U.S. Holders**”) at a price of U.S. \$ 5.50 per Share to all holders of Shares resident in the United States of America (the “**U.S. Offer**”). U.S. Holders may only tender their Shares to the U.S. Offer.

The U.S. Offer is made in the United States, where the NASDAQ is located, principal trading market of the Shares. Pursuant to requirements of U.S. law, the U.S. Offer must remain open for at least 20 business days, the offer is centralized and any U.S. Holder is permitted to withdraw Shares previously tendered until expiration of the U.S. Offer. So that shareholders are treated equally in the U.S. Offer and the Offer (which is required by U.S. regulations), by way of derogation from articles 233-1 1° and following of the General Regulation of the AMF and as explained in more details in part III of this draft offer memorandum, the Offer (i) will last 22 trading days, (ii) be centralized by Euronext Paris and (iii) the sale orders will be revocable at any time until the last day of the Offer.

Holders of Shares who are not resident in France or in the United States may tender their Shares in the Offer as long as the laws and regulations applicable to such holders authorize them to do so and under their responsibility.

1. PRESENTATION OF THE COMPANY, BACKGROUND AND RATIONALE FOR THE REORGANIZATION AND THE TRANSACTION

1.1 Context of the Offer

The following summarizes the significant events that led to the signing of the Reorganization Agreement (as defined below) and to the launch of the Offers, without pretending to represent the exhaustiveness of the exchanges between the concerned parties.

Cnova was incorporated on May 30, 2014, as a public limited liability company (*naamloze vennootschap*) organized under the laws of the Netherlands. In July 2014, Cnova completed the reorganization of the eCommerce businesses of Casino and its affiliated entities in France and Brazil, including CBD and Via Varejo. Following the completion of this initial reorganization, Cnova owned, directly or indirectly, substantially all of the assets that were used in the non-food eCommerce businesses of Casino, CBD and Via Varejo. On November 25, 2014, Cnova completed the initial public offering of its Shares, which began trading on NASDAQ on that date. On January 23, 2015, the Shares began trading on Euronext Paris under the ticket symbol “CNV”, with Morgan Stanley & Co. LLC, J.P. Morgan Securities LLC, Merrill Lynch, Pierce, Fenner & Smith Incorporated, Credit Suisse Securities (USA) LLC and Deutsche Bank Securities Inc. acting as *bookrunners*, and BNP Paribas Securities Corp., HSBC Securities (USA) Inc., Natixis Securities Americas LLC and SG Americas Securities LLC acting as co-manager of the offer.

*Translation for information purposes only.
In case of discrepancy between the French and the English version, the French version shall prevail.*

This Offer and this draft offer document are subject to the review of the AMF

The senior management and the boards of directors of Casino and Cnova actively monitor and assess developments in the online retail industry, as well as economic and business trends in Brazil and France, which are the primary markets in which Cnova used to compete. In addition, the senior management of Via Varejo and its board of directors actively monitor and assess developments in the Brazilian brick-and-mortar retail industry, as well as overall economic and business trends in Brazil. Casino, as the controlling shareholder of its group of affiliated companies (the “**Casino Group**”), periodically reviews the performance of the affiliated entities within its affiliated companies, including Cnova and Via Varejo, and regularly assesses opportunities to improve the competitive position and business strategy of the Casino Group, as well as to maximize operating synergies among the Casino Group companies.

Late December of 2015 and January and February of 2016, representatives of Casino, including Jean-Yves Haagen, Group General Counsel and Luis Enrique Devis, Director of Corporate Development and Holdings – Latam, and representatives of Cnova, including Stéphane Brunel (then Deputy Chief Financial Officer of Cnova, at present Chief Financial Officer of Cnova), and Steven Geers, General Counsel of Cnova, evaluated potential transaction structures that would permit the combination of Cnova’s Brazilian eCommerce business with Via Varejo. To assist in the legal aspects of this review, Casino and Cnova engaged Darrois Villey Maillot Brochier (“**Darrois**”), NautaDutilh N.V. (“**NautaDutilh**”), Trindade Sociedade de Advogados, (“**Trindade**”), Lefosse Advogados (“**Lefosse**”), and Wachtell, Lipton, Rosen & Katz, (“**Wachtell Lipton**”), as legal advisors.

On March 3, 2016, the Cnova board of directors met telephonically, discussed a broad outline of the proposed transactions, and met telephonically with members of Cnova’s management and representatives of BNP Paribas, financial advisors to Cnova, and a representative of Eight Advisory France S.A.S. (“**Eight Advisory**”). During this meeting, the following Cnova’s board of directors members determined that, in light of the relationships between Cnova, CBD, Via Varejo and their controlling shareholder, Casino, each of the following members of Cnova’s board of directors recused themselves from participating in any further deliberations and decision making in connection with the Transactions: Peter Estermann, Didier Lévêque, Ronaldo Iabrudi do Santos Pereira, Eleazar de Carvalho Filho, Yves Desjacques, Antoine Giscard d’Estaing and Arnaud Strasser. The Cnova board of directors then approved the formation of a Transaction Committee for purposes of evaluating, negotiating and entering into agreements in connection with the Transactions, which is referred to herein as the “**Cnova Transaction Committee**”, consisting of Silvio J. Genesini, Bernard Oppetit and Cnova’s chief executive officer, Emmanuel Grenier. The other members of the Cnova board of directors then left the meeting.

The Cnova Transaction Committee subsequently discussed with representatives of management and BNP Paribas, the strategic rationale of a series of transactions that would combine the business of Via Varejo and Cnova Brazil, including, among other things, the operational difficulties experienced by Cnova Brazil and refocusing Cnova on the Cdiscount business in France, where Cdiscount has a market-leading position and a demonstrated capacity for expanding market share. The Cnova Transaction Committee retained Freshfields Bruckhaus Deringer LLP (“**Freshfields**”), as independent counsel to the Cnova Transaction Committee, and Eight Advisory as independent valuation expert to the Cnova Transaction Committee in connection with its evaluation of the proposed Transactions. In addition to representatives of the aforementioned financial advisors, representatives of Darrois, Lefosse, NautaDutilh, Trindade and Wachtell Lipton, were also present at the meeting. At the conclusion of this meeting, the Cnova Transaction Committee directed Cnova’s management to explore further the proposed Transactions and to develop a review of any other strategic alternatives available to Cnova, to be presented to the Cnova Transaction Committee.

*Translation for information purposes only.
In case of discrepancy between the French and the English version, the French version shall prevail.*

This Offer and this draft offer document are subject to the review of the AMF

On March 9, 2016 and March 15, 2016, the Cnova Transaction Committee met telephonically with members of Cnova's management and representatives of BNP Paribas. Representatives of Freshfields also participated in the calls. During these meetings, Stéphane Brunel, presented a number of strategic alternatives to the Cnova Transaction Committee, including (a) the possibility of a sale of Cnova Brazil to an unaffiliated third party, (b) the possibility of an exchange offer by Via Varejo in connection with Via Varejo's acquisition of Cnova Brazil, (c) the sale of Cnova Brazil to Via Varejo for cash, together with a possible share buyback by Cnova or a special dividend of the cash proceeds of the transaction, (d) a tender offer by Casino for Shares followed by an indirect merger of Cnova Brazil into Via Varejo and the cancellation of Via Varejo's interest in Cnova and (e) the indirect merger of Cnova Brazil into Via Varejo, followed by a tender offer by Casino for Shares and a cancellation of Via Varejo's interest in Cnova.

During these meetings, the Cnova Transaction Committee discussed the advantages and disadvantages of each of these potential strategic alternatives. The Cnova Transaction Committee eliminated the possibility of a sale to a third party outside the CBD and its group of affiliated companies because of the loss of brands and other intellectual property licensed from CBD and Via Varejo would be likely to destroy value in the business. The Cnova Transaction Committee also eliminated the possibility of an exchange offer by Via Varejo in consideration of its acquisition of Cnova Brazil because of the timing implications and legal complexities involved in conducting an exchange offer in the United States, which Via Varejo would be required to register under the U.S. Securities Act of 1933, as amended, and which would result in Via Varejo having ongoing reporting obligations in the United States under the U.S. Securities Exchange Act of 1934, as amended. The Cnova Transaction Committee determined not to pursue a cash sale of Cnova Brazil to Via Varejo because it was informed by Cnova's management that Via Varejo would be unable to fund adequate cash consideration. After extensive discussion, the Cnova Transaction Committee ultimately determined that the possibility of a reorganization of the Cnova Brazil business within Via Varejo, by means of an indirect merger, followed by a cancellation of Via Varejo's interest in Cnova, together with a tender offer by Casino for Cnova's Shares, would be the best available strategic alternative for Cnova and Cnova Brazil. The Cnova Transaction Committee preferred this alternative because of the significant operational synergies between Cnova Brazil and Via Varejo, the simplification of the Cnova holding structure, which would focus entirely on Cdiscount following the completion of the transaction, and the relatively expeditious timeline for completing such a transaction.

*Translation for information purposes only.
In case of discrepancy between the French and the English version, the French version shall prevail.*

This Offer and this draft offer document are subject to the review of the AMF

In determining to require that Casino undertakes a tender offer for Shares, conditioned only on completion of the proposed reorganization, the Cnova Transaction Committee noted that, as a result of the completion of the proposed reorganization, the business profile of Cnova would be significantly altered and investors may prefer to receive a fixed cash payment for their Shares, rather than retaining an interest in Cnova. The Cnova Transaction Committee also noted its expectation that the liquidity of Shares on NASDAQ and Euronext Paris would be significantly reduced if the Offers were successful. The Cnova Transaction Committee stated its expectation that the price to be offered by Casino in the Offers would reflect full and fair value for the Shares. Finally, in connection with the potential transaction, BNP Paribas discussed historical trading prices per share for Shares and target prices for Shares based on publicly available equity research estimates.

On March 25, 2016, the Cnova Transaction Committee met telephonically with members of Cnova's management and representatives of BNP Paribas. Representatives of Freshfields also participated in the call, together with representatives of Darrois and NautaDutilh. The meeting participants were provided with a preliminary draft of the valuation report of BNP Paribas, which report included preliminary valuations of Cnova Brazil, Cdiscount and Cnova on a consolidated basis. After reviewing these preliminary valuations, the members of the Cnova Transaction Committee indicated their belief that, based on the Cnova business plan and the financial advisors' extrapolation period projections, the valuation of Cnova on a per share basis should reflect a very significant premium to the market price of Cnova's Shares.

On March 27, 2016, representatives of Casino and Cnova sent a draft of a non-binding memorandum of understanding with respect to the proposed reorganization to members of Via Varejo's management and Via Varejo's legal advisors. The draft memorandum of understanding provided for Cnova Brazil to be reorganized within Via Varejo through a series of corporate transactions, pursuant to which Via Varejo's approximately 21.9% indirect interest in Cnova would be cancelled. The draft memorandum of understanding provided for indemnification obligations of Cnova, the amount of which, if payable, would be reduced by 21.9% in respect of the portion of any loss corresponding to Via Varejo's level of ownership in Cnova prior to the completion of the transaction. The draft memorandum of understanding also provided that Cnova would not have any liability for indemnification in respect of conduct occurring prior to October 17, 2013, the date on which the Casino Group initially acquired control of Cnova Brazil from Via Varejo.

On March 31, 2016 and April 1, 2016, a representative of Via Varejo met with Mr. Devis, Rafael Russowsky and Mr. Brunel, together with representatives of Darrois, Lefosse, NautaDutilh, Trindade and Wachtell Lipton, to discuss the draft memorandum of understanding. The parties discussed the draft memorandum of understanding and, in particular, the approach to indemnification set forth therein. The parties discussed whether the limitation on Cnova's indemnification obligations in respect of Via Varejo's pre-transaction ownership might be acceptable to Via Varejo. The parties also discussed that Via Varejo would not likely accept a limitation of Cnova's indemnification obligations in respect of the period prior to Casino Group obtaining control of the operations of the Cnova Brazil business.

*Translation for information purposes only.
In case of discrepancy between the French and the English version, the French version shall prevail.*

This Offer and this draft offer document are subject to the review of the AMF

On April 13, 2016, the Cnova Transaction Committee met with members of Cnova's management, representatives of BNP Paribas and representatives of Eight Advisory at BNP Paribas's office in London. A representative of Freshfields also participated in the meeting, together with representatives of Darrois and NautaDutilh. Mr. Brunel explained that, based on discussions in prior meetings and updated market data, BNP Paribas had revised its draft valuation report to reflect revised preliminary valuations of Cnova Brazil, Cdiscount and Cnova on a consolidated basis. At the meeting, BNP Paribas discussed these preliminary valuations, including the ranges of equity value per share that such preliminary valuations implied.

On April 18, 2016, representatives of Casino and Cnova sent a revised draft of the memorandum of understanding with respect to the proposed reorganization to members of Via Varejo's management and Via Varejo's legal advisors, reflecting Casino and Cnova's positions with respect to the proposed transaction.

On April 28, 2016, in response to speculation in the press related to a potential transaction involving Via Varejo and Cnova Brazil, Via Varejo and Cnova issued a press release confirming that the companies were reviewing, together with certain of their affiliates, the viability of and interest in a potential reorganization in which Cnova Brazil would be reorganized within Via Varejo.

On May 3, 2016, the Cnova Transaction Committee met in Paris, joined by representatives from Cnova management, representatives of Casino, BNP Paribas, Eight Advisory and Freshfields, with representatives of Darrois and NautaDutilh joining by telephone. During this meeting, the members of the Cnova Transaction Committee reiterated their support for the further exploration of the proposed Transactions and determined that the Cnova Transaction Committee required that the price offered by Casino in the Offers be US\$5.50 per Share in order for the Cnova Transaction Committee to be able to support the proposed Reorganization.

On May 5, 2016, in response to continued rumors in the press relating to a potential transaction, at the instruction of Via Varejo's management and the Cnova Transaction Committee, Cnova's and Via Varejo's respective legal advisors discussed a short-form version of the draft memorandum of understanding with respect to the proposed reorganization, which would set forth the economic terms of the proposed reorganization and an agreed-upon valuation range for Cnova Brazil for purposes of the proposed reorganization, and would defer negotiation of other provisions of a definitive Reorganization Agreement, including the content of the representations and warranties, interim operating covenants and indemnification provisions, to a later date. Via Varejo and the Cnova Transaction Committee instructed their advisors to proceed with the negotiation of such a short-form non-binding memorandum of understanding.

On May 10, 2016, the audit committee of the Casino board of directors, which is referred to herein as the "**Casino audit committee**" and the "**Casino board**", respectively, met with members of Casino's management, representatives of Rothschild & Co Banque ("**Rothschild**"), and Crédit Agricole Corporate & Investment Bank ("**CACIB**"), financial advisors to Casino, as well as representatives of Messier Maris & Associés ("**MMA**"), special financial advisor to the Casino audit committee, to review the terms of the proposed Reorganization and the Offers. Representatives of Darrois, legal advisor to Casino and Cnova, also attended the meeting. Representatives of Casino's management and of Darrois gave the members of the Casino audit committee an overview of the proposed Transactions, of the proposed non-binding memorandum of understanding and of the commitment letter whereby Casino would undertake to Cnova that, should the proposed reorganization be completed, Casino would launch tender offers in the United States and outside of the United States, with an offer price of US\$5.50 per Share. Representatives of Rothschild and CACIB presented their conclusions, as set forth in their preliminary joint valuation report, reflecting valuations of Cnova Brazil, Cdiscount and Cnova on a consolidated basis. A representative of MMA then stated that, as of such date and based upon and subject to the assumptions made, procedures followed, matters considered and qualifications and limitations described in the MMA valuation report, the analysis and the results presented by the Casino financial advisors in the Casino financial advisors valuation report were consistent with the analysis performed by MMA and that the Casino financial advisors' analysis had been conducted in accordance with the methods upon which MMA has no comments other than those summarized in the MMA report. On this basis, the Casino audit committee determined to recommend the terms of the proposed Transactions, including the terms of the proposed reorganization set forth in the non-binding memorandum of understanding, and the tender offers to the full Casino board.

*Translation for information purposes only.
In case of discrepancy between the French and the English version, the French version shall prevail.*

This Offer and this draft offer document are subject to the review of the AMF

On May 11, 2016, Via Varejo's board of directors, which is referred to herein as the "**Via Varejo board**", met and determined, in accordance with Via Varejo's policy for related party transactions, to create a special committee composed of a majority of independent directors, in order to analyze the terms and conditions of the proposed reorganization, to negotiate the final Reorganization Agreement (as it is defined below) and to issue a recommendation to the Via Varejo board regarding the proposed Reorganization and the new operational agreement to be entered into between CBD and Via Varejo in connection with the proposed Reorganization. The Via Varejo board appointed Alberto Guth, Renato Carvalho do Nascimento and Christophe Hidalgo to the newly formed Via Varejo special committee, which is referred to herein as the "**Via Varejo special committee**".

Also on May 11, 2016, pursuant to the shareholders agreement in place among the shareholders of Via Varejo a the representatives of CBD and of the CB Group (a group of shareholders of Via Varejo that is unaffiliated with Casino, CBD and Cnova, consisting of Mr. Michael Klein and the companies EK VV Limited, Bahia VV RK Limited, Bahia VV NK Limited, Altara RK Investments Limited and Altara NK Investments Limited, collectively holding approximately 27.3% of the outstanding share capital of Via Varejo as of September 29, 2016) approved a shareholders' resolution. Pursuant to the shareholders' resolution: (i) CBD committed to not exercise its voting rights at the meeting of Via Varejo's shareholders in connection with the proposed reorganization, in order to enhance the independence of the approval of the Via Varejo shareholders by effectively granting Via Varejo's minority shareholders the power to approve or reject the proposed reorganization; and (ii) the CB Group committed to vote in favor of the proposed reorganization at such meeting provided that the Via Varejo special committee unanimously recommends such a vote.

Also on May 11, 2016, CBD's board of directors met and decided, in compliance with CBD's policy for related party transactions, to create a special committee composed of a majority of independent directors, in order to analyze the terms and conditions of the proposed Transactions and issue a recommendation to CBD's board of directors regarding (i) the vote to be cast by CBD at the meeting of Cnova's shareholders in connection with the proposed reorganization; (ii) whether or not CBD would agree not to tender its Shares into the Offers; and (iii) the terms and conditions of the new operational agreement to be entered into between CBD and Via Varejo in connection with the completion of the proposed reorganization. The CBD board of directors named board members Eleazar de Carvalho Filho, Maria Helena S. F. Santana and Luiz Aranha Corrêa do Lago as the members of the CBD special committee (the "**CBD special committee**").

Also on May 11, 2016, the Cnova Transaction Committee met telephonically with members of Cnova's management, representatives of BNP Paribas and representatives of Eight Advisory. Representatives of Freshfields also participated in the call, together with representatives of Darrois and NautaDutilh. A representative of BNP Paribas presented a revised draft valuation report based on current market information. The representative of BNP Paribas discussed with the Cnova Transaction Committee these updated preliminary valuations, including the ranges of equity value per Share that such updated preliminary valuations implied. Further, Eight Advisory also presented its preliminary valuation report, reflecting valuations for Cnova Brazil, Cdiscount and Cnova on an unconsolidated basis (after taking account of overhead and other operational holding costs). The representatives of Casino also confirmed that Casino had agreed to launch a tender offer at a price of US\$5.50 per Share should the proposed reorganization be completed, as set forth in a draft commitment letter from Casino to the Cnova Transaction Committee. The Cnova Transaction Committee thereafter resolved to authorize Cnova's management to execute the non-binding memorandum of understanding and to enter into negotiations with respect to definitive transaction documentation on the basis of the memorandum of understanding.

*Translation for information purposes only.
In case of discrepancy between the French and the English version, the French version shall prevail.*

This Offer and this draft offer document are subject to the review of the AMF

Later on May 11, 2016, after the meetings of the Via Varejo board and the Cnova Transaction Committee, Casino delivered a commitment letter to Cnova regarding the Offers to be undertaken following completion of the proposed Reorganization and Cnova and Via Varejo executed the non-binding memorandum of understanding regarding the proposed reorganization. Following the execution of these agreements, Via Varejo, Cnova and Casino issued press releases disclosing the proposed Transactions and the execution of the non-binding memorandum of understanding.

On May 20, 2016, the Via Varejo special committee held a conference call to discuss the scope of work that would be carried out by the Via Varejo special committee in connection with the evaluation of the proposed reorganization and the engagement of independent external financial and legal advisors. They were joined by Peter Estermann, chief executive officer of Via Varejo, and André Rizk, general counsel of Via Varejo. The Via Varejo special committee later engaged Banco Santander (Brasil) S.A. ("**Santander**") as its external and independent financial advisor and Yazbek Advogados ("**Yazbek**"), and Campos Mello Advogados, ("**Campos Mello**"), as independent legal advisors.

On June 8, 2016, the Cnova Transaction Committee met in São Paulo, Brazil, and was joined in person by Steven Geers, general counsel of Cnova, Messrs. Devis and Russowsky, representatives of Casino, and representatives of Trindade. Mr. Brunel and representatives of BNP Paribas and Freshfields attended the meeting by telephone. During this meeting, the Cnova Transaction Committee received an update on the ongoing negotiations with the Via Varejo special committee and its advisors.

On June 20, 2016, the Via Varejo special committee met by videoconference, together with a representative of Campos Mello. At this meeting, the Via Varejo special committee determined the scope of due diligence to be undertaken in connection with the proposed reorganization; (i) the engagement of a consultant to carry out financial and accounting due diligence with respect to Cnova Brazil; and (ii) the engagement of Davis Polk & Wardwell LLP ("**Davis Polk**"), as special counsel for matters of U.S. law, in particular with respect to certain litigation then-pending against Cnova and in connection with the negotiation and drafting of a definitive Reorganization Agreement.

This Offer and this draft offer document are subject to the review of the AMF

On June 21, 2016, the Via Varejo special committee and its legal advisors met in São Paulo, and were joined by André Rizk, then-general counsel of Via Varejo, Messrs. Devis and Russowsky and representatives of Trindade and Lefosse. During this meeting, the Via Varejo special committee received an update with respect to the ongoing investigation of certain accounting matters with respect to Cnova Brazil and related litigation.

On June 23, 2016, the Via Varejo special committee, Campos Mello and Yazbek met in São Paulo, and were joined by Messrs. Devis and Russowsky and by representatives of Trindade and Lefosse, to discuss the terms of the draft Reorganization Agreement, particularly the proposed limitations on Cnova's indemnification obligations. The members of the Via Varejo special committee expressed their continued view that Cnova should indemnify Via Varejo with respect to conduct arising prior to the Casino Group obtaining control over the operations of the Cnova Brazil business. The members of the Via Varejo special committee and the representatives of Casino also discussed whether or not Cnova's indemnification obligations under the Reorganization Agreement would be subject to a cap. The members of the Via Varejo special committee indicated that the concept of a cap would be acceptable, subject to specified exceptions and if the cap was of a large enough amount.

On July 6, 2016, legal advisors to Via Varejo's special committee provided Casino's and Cnova's legal advisors with a revised draft of the Reorganization Agreement. Among other provisions, the draft provided that Casino would be a party to the Reorganization Agreement as a guarantor of Cnova's obligations thereunder, removed limitations on indemnification and expanded the representations and warranties to be made by Cnova in respect of Cnova Brazil's business. The revised draft also provided for an adjustment to the balancing payment based on a full reconciliation of the balance sheet of Cnova Brazil at the completion of the Reorganization.

On July 12, 2016, the Via Varejo special committee and its legal advisors met in São Paulo with Mr. Devis and representatives of Trindade and Lefosse. The parties discussed the status of the negotiation of the draft Reorganization Agreement and the schedule for the finalization of Cnova's restated financial statements. The parties further discussed the terms of the draft Reorganization Agreement that remained under negotiation. In particular, the parties discussed whether Casino would be a party to the Reorganization Agreement; whether the Reorganization Agreement would include a balancing payment adjustment; whether Cnova would be responsible to Via Varejo for indemnification with respect to conduct that occurred prior to the Casino Group obtaining control over the business of Cnova Brazil; and whether other indemnification limitations should be included in the Reorganization Agreement. These positions were discussed among Mr. Devis, the members of the Via Varejo special committee and their respective advisors. The status of Via Varejo's due diligence and the draft operational agreement were also discussed.

On July 15, 2016, the Cnova Transaction Committee met by telephone, together with members of Cnova's and Casino's management, the legal advisors to Cnova and Casino and representatives of Freshfields, the legal advisor to the Cnova Transaction Committee. A representative of Trindade updated the members of the Cnova Transaction Committee on the key issues raised by Via Varejo's most recent draft of the Reorganization Agreement (as it is defined below) as well as the key points of disagreement discussed during the July 12, 2016 meeting between Cnova's legal advisors and the legal advisors to the Via Varejo special committee. In particular, the members of the Cnova Transaction Committee were informed that the Via Varejo special committee was unlikely to accept an exclusion from indemnification for items occurring prior to the Casino Group gaining control over the business of Cnova Brazil in October 2013. Mr. Brunel discussed with the members of the Cnova Transaction Committee the challenges posed by Via Varejo's request for a balancing payment adjustment and the various methods of making such an adjustment. The Cnova Transaction Committee requested that Cnova's financial advisors undertake a review of possible balancing payment adjustment methodologies in order to make a recommendation on a methodology that would be fair to both Cnova and Via Varejo. The members of the Cnova Transaction Committee and the advisors also discussed alternative approaches that might allow the proposed reorganization to proceed without a balancing payment adjustment, including the possibility of adopting a locked box mechanism.

*Translation for information purposes only.
In case of discrepancy between the French and the English version, the French version shall prevail.*

This Offer and this draft offer document are subject to the review of the AMF

During the morning of July 25, 2016, the members of the Cnova Transaction Committee met telephonically, together with representatives of Freshfields, representatives of Cnova's and Casino's management, representatives of Eight Advisory, representatives of BNP Paribas and representatives of Cnova's and Casino's legal advisors, including Darrois, Lefosse, NautaDutilh, Trindade and Wachtell Lipton. A representative of BNP Paribas presented an overview of possible balancing payment adjustment methodologies, noting the advantages and disadvantages of the various methodologies to Cnova. After a detailed discussion of these alternatives, the Cnova Transaction Committee instructed management and the advisors to negotiate a balancing payment adjustment based on differences in the working capital and net debt positions of Cnova Brazil as compared to forecasted targets as of the applicable Reorganization Date.

During the afternoon of July 25, 2016, Messrs. Genesini, Devis and Russowsky, together with representatives of Darrois, Lefosse, Trindade, NautaDutilh and Wachtell Lipton met with the Via Varejo special committee, together with representatives of Campos Mello, Yazbek and Davis Polk to discuss the principal open terms of the draft Reorganization Agreement. The discussions included the possibility of an adjustment to the cash portion of the consideration to be paid by Via Varejo to Cnova in the proposed reorganization, which adjustment would be based on Cnova Brazil's working capital and net debt positions, and the limitations on Cnova's indemnification obligations under the draft Reorganization Agreement. Later on July 25, 2016, following this meeting, Cnova's legal advisors delivered a marked-up draft of the draft Reorganization Agreement to Via Varejo's legal advisors, reflecting the negotiating positions that had been described to the Via Varejo special committee and its legal advisors earlier that day.

Also on July 25, 2016, the Via Varejo special committee engaged the law firm De Brauw Blackstone Westbroek, for support in connection with the proposed reorganization with respect to matters of Dutch law.

On July 26, 2016, Messrs. Devis, Russowsky and Brunel, representatives of Via Varejo, representatives of BNP Paribas, and representatives of Santander spoke by telephone and discussed possible approaches to adjusting the amount of the cash consideration to be paid by Via Varejo to Cnova in the proposed reorganization, including the economic basis of the target net debt and working capital against which any such adjustment would be measured. The representatives of Santander indicated that, subject to review and confirmation by Santander and the members of the Via Varejo special committee of the projections of Cnova Brazil's working capital and net debt position through the likely Reorganization Date, the concept of a working capital and net debt adjustment would be acceptable to Via Varejo.

*Translation for information purposes only.
In case of discrepancy between the French and the English version, the French version shall prevail.*

This Offer and this draft offer document are subject to the review of the AMF

On July 27, 2016, the Casino audit committee met with members of Casino's management and representatives from Darrois to discuss, among other things, the request of the Via Varejo special committee that Casino execute the draft Reorganization Agreement, for the purpose of guaranteeing Cnova's obligations thereunder. Representatives of Casino's management and representatives of Darrois were present by phone. After discussing the matter with members of Casino's management and Casino's legal advisors, the Casino audit committee agreed with management's recommendation, but that Casino offer to support Cnova's indemnification obligations through the provision of a separate limited guarantee, up to a maximum amount of U.S. \$60 million, instead of Casino being a party to the Reorganization Agreement.

On July 28, 2016, the Via Varejo special committee met with Campos Mello and Yazbek in order to discuss the pending issues concerning the Reorganization Agreement, including the guarantee sought from Casino and the balancing payment adjustment mechanism and indemnity provision.

On July 28, 2016, the members of the Cnova Transaction Committee, together with representatives of Cnova management, Messrs. Devis and Russowsky and representatives of Darrois, Lefosse, NautaDutilh, Trindade and Wachtell Lipton, held a call with representatives of the Via Varejo special committee and their legal advisors from Campos Mello and Yazbek. Casino and Cnova's legal advisors explained that Casino preferred not to be a party to the draft Reorganization Agreement, as well as the view of Casino and Cnova that, in light of the substantial assets and continuing business of Cnova following the completion of the proposed transaction, no guarantee from Casino should be necessary because Cnova would have adequate assets to support its obligations following closing. The parties also discussed the scope of Cnova's indemnification obligations and the balancing payment adjustment mechanism. The Via Varejo special committee agreed to review the latest draft of the Reorganization Agreement provided by Cnova. The representatives of Casino indicated that, in light of the importance of the guarantee to the Via Varejo special committee, Casino's board would discuss the matter.

On July 29, 2016, the Casino board discussed Via Varejo's request for a guarantee and approved, among other things, the provision to Cnova of a separate limited guarantee (or, if so determined, a letter of credit from an internationally recognized banking institution), up to a maximum amount of US\$60 million, which could be used to Cnova's indemnification obligations under the draft Reorganization Agreement. The Casino Board also received updated information about the progress of the negotiations and the different contracts to which Casino would be a party as part of the Transactions.

On July 30, 2016, the Cnova Transaction Committee held a meeting by telephone joined by representatives of Cnova management, of Eight Advisory and the committee's legal advisors, and also was attended by representatives of BNP Paribas, during which BNP Paribas and Eight Advisory provided their respective updated preliminary analyses on the valuation of Cnova, Cnova Brazil and Cdiscount. The committee reviewed and discussed the updated preliminary analyses and provided feedback.

Also on July 30, 2016, the Via Varejo special committee and its legal advisors held a conference call in order to resolve on the proposals received from Cnova, in light of the discussions held on the previous days. The Via Varejo special committee concluded that such proposals were, in concept, consistent with the interests of Via Varejo's shareholders and, therefore, resolved to accept the concept of a balancing payment adjustment and Cnova's proposal that, instead of Casino being party to the proposed reorganization, Casino would provide support for Cnova's indemnification obligations through alternate means including a guarantee. The Via Varejo special committee then discussed the pending issues concerning the indemnity provision contained in the draft Reorganization Agreement, including the scope of the limitations thereon.

*Translation for information purposes only.
In case of discrepancy between the French and the English version, the French version shall prevail.*

This Offer and this draft offer document are subject to the review of the AMF

On August 3, 2016, the Via Varejo special committee held a conference call with their legal advisors in order to discuss their additional comments to the draft Reorganization Agreement. On the same date, representatives of Davis Polk delivered a marked-up draft of the Reorganization Agreement to representatives of Wachtell Lipton, reflecting the outcome of the parties' conversation on July 28, 2016.

On August 4, 2016, the Via Varejo special committee met with representatives of Santander, Campos Mello and Yazbek, in order to analyze the draft financial analysis report prepared by Santander and the adjustments made in view of Cnova's recent restatement of its financial statements following the conclusion of its internal investigation into certain accounting concerns at Cnova Brazil, and the revised business plans of Cnova and Cnova Brazil. The Via Varejo special committee posed several questions to Santander, including with respect to synergies and the adjustments made due to the results of an accounting investigation at Cnova Brazil.

Also on August 4, 2016, representatives of Davis Polk, Campos Mello and Yazbek met with Mr. Geers, general counsel of Cnova, and representatives of Darrois, Lefosse, NautaDutilh, Trindade and Wachtell Lipton to negotiate the legal terms of the draft Reorganization Agreement. The members of the Via Varejo special committee and Messrs. Devis and Russowsky also joined the meeting by telephone. During this meeting, the parties agreed that Cnova would agree to indemnify Via Varejo for certain liabilities of Cnova Brazil related to consumer claims and labor matters, as more specifically set forth in the Reorganization Agreement. The parties also agreed on which components of Cnova's indemnification obligations would be subject to the aggregate cap on liability and that Cnova would place a portion of the cash to be received at the completion of the proposed reorganization into escrow, in support of Cnova's indemnification obligations to Via Varejo under the draft Reorganization Agreement. Following this meeting, Wachtell Lipton circulated a revised draft of the Reorganization Agreement to the Via Varejo special committee's legal advisors.

On August 5, 2016, Mr. Devis and the members of the Via Varejo special committee engaged in a discussion of the financial terms of the proposed reorganization. They agreed that the proposed Reorganization would estimate an equity value of Cnova equal to approximately U.S. \$2.2 billion and an equity value of Cnova Brazil equal to approximately U.S. \$489.0 million. Based on these valuations and on the outstanding principal and interest on existing loan agreements existing loan agreements between Cnova Brazil, Cnova and Cnova Finança, a *besloten vennootschap met beperkte aansprakelijkheid* organized under the law of the Netherlands ("**Cnova Finança**") equal to approximately U.S. \$156.0 million, the parties agreed that Via Varejo would make a cash payment to Cnova in the amount of approximately R\$16.5 million. These amounts were within the valuation ranges set forth in the non-binding memorandum of understanding and were agreed on the basis of an exchange rate of 3.2763 R\$/U.S. \$, as set forth in the Reorganization Agreement.

*Translation for information purposes only.
In case of discrepancy between the French and the English version, the French version shall prevail.*

This Offer and this draft offer document are subject to the review of the AMF

Over the course of August 5, 6 and 7, 2016, the parties and their legal advisors finalized the remaining terms of the draft Reorganization Agreement, including the remaining open points with respect to Cnova's indemnification obligations and the limitations on such obligations pursuant to the Reorganization Agreement.

During the morning of August 8, 2016, CBD's board of directors met, and the CBD special committee submitted its considerations and conclusions to the CBD board of directors, including its unanimous recommendation in favor of (i) CBD's vote in favor of approval of the Reorganization at the extraordinary general meeting of Cnova shareholders ("**Cnova EGM**"); and (ii) CBD agreement not to tender its Shares in the Offers. In light of the favorable recommendation of CBD's special committee, and considering that Casino submitted a commitment letter to CBD, pursuant to which Casino has granted CBD certain governance and liquidity rights in relation to the interest held by CBD in Cnova, CBD's board of directors resolved that CBD shall vote in favor of approval of the Reorganization at the Cnova EGM and that CBD shall not tender its Shares in the Offers. CBD's board of directors also confirmed its prior resolution that CBD shall not exercise its voting rights with respect to the Reorganization at the extraordinary general meeting of the Via Varejo shareholders.

Also during the morning of August 8, 2016, a meeting of Via Varejo's Board of Directors was held at which representatives of Santander, Campos Mello and Yazbek were present, in which the Via Varejo special committee submitted its considerations and conclusions to Via Varejo's Board of Directors, as well as its unanimous recommendation in favor of the implementation of the proposed reorganization and the execution of the proposed Reorganization Agreement. In light of the Via Varejo special committee's favorable recommendation, Via Varejo's Board of Directors resolved to approve (i) the execution of the draft Reorganization Agreement with Cnova Brazil and Cnova NV, as well as (ii) the convening of an extraordinary general shareholders meeting in order to submit the proposed reorganization to the approval of, holders of Via Varejo's common and preferred shares. The Via Varejo Board further approved the submission of Via Varejo's new stock option compensation plan to Via Varejo's shareholders for approval. The Via Varejo Board also approved, following the recommendation of the Via Varejo special committee, the execution of the new operational agreement between CBD and Via Varejo. Following this meeting, CBD and Via Varejo executed the new operational agreement (the "**Reorganization Agreement**").

Later on August 8, 2016, after Casino had executed a letter agreement memorializing its undertaking to launch the Offers (the "**Casino-Cnova Undertakings Letter**"), the Cnova Transaction Committee met by telephone, together with members of Cnova's management and representatives of BNP Paribas, Eight Advisory, Freshfields, Darrois, Lefosse, NautaDutilh, Trindade and Wachtell Lipton, to discuss and review the negotiated terms of the proposed reorganization transaction. Mr. Brunel presented an overview of recent negotiations with the Via Varejo special committee. A representative of Wachtell Lipton reviewed the terms of the draft Reorganization Agreement that had been negotiated with the Via Varejo special committee and its counsel, including the indemnification terms, the terms of the escrow arrangements and the mechanics of the working capital and net debt adjustment. A representative of Lefosse described certain of the termination provisions contained in the draft Reorganization Agreement. A representative of BNP Paribas made a presentation concerning its revised valuation of Cnova, Cnova Brazil and Cdiscount. Following the presentation by BNP Paribas, a representative of Eight Advisory made a financial presentation concerning the proposed reorganization and delivered its independent expert report on the financial terms of the proposed reorganization, including its opinion that, as of August 8, 2016 and based upon, and subject to, the factors and assumptions set forth therein, the consideration to be received by Cnova pursuant to the Reorganization Agreement (as it is defined below) was fair, from a financial point of view, to Cnova minority shareholders. A representative of Freshfields then reviewed with the directors the legal standards applicable to their decisions and actions with respect to the proposed reorganization. Following discussions and deliberations, including a determination that the Cnova Transaction Committee had made a thorough assessment of the Reorganization as compared to other strategic alternatives and having thoroughly considered the merits, advantages and potential disadvantages of the Transactions, and considering the interests of Cnova and its stakeholders, including Cnova's minority shareholders, the Cnova Transaction Committee, representing the Cnova board of directors, unanimously (i) determined that the Transactions are in the best interests of Cnova, its shareholders and all other stakeholders, (ii) determined that the Transactions are fair, advisable and in the best interests of unaffiliated Cnova shareholders, (iii) resolved to enter into the Transactions and (iv) resolved to recommend that the holders of Shares approve the Reorganization and directed that the Reorganization be submitted to Cnova's general meeting of shareholders for its approval.

*Translation for information purposes only.
In case of discrepancy between the French and the English version, the French version shall prevail.*

This Offer and this draft offer document are subject to the review of the AMF

Following the meeting of the Cnova Transaction Committee, (i) Cnova, Cnova Brazil and Via Varejo executed the Reorganization Agreement, (ii) Cnova released its signature to the Casino-Cnova Undertakings Letter, (iii) Casino and CBD executed the Casino-CBD Commitment Letter (as defined in section 1.3 of this draft offer memorandum) and (iv) CBD executed the CBD Support Letter, the terms of which are more fully described below in section 1.3 of this draft offer memorandum.

Following the close of trading on the NASDAQ of August 8, 2016, Casino, Cnova, Via Varejo and CBD issued press releases announcing the execution of the Reorganization Agreement and the Reorganization and Casino's agreement, subject to the completion of the Reorganization, to undertake the Offers.

On August 11, 2016, Via Varejo published the notice of an extraordinary general meeting of the Via Varejo shareholders, at which Via Varejo's shareholders would be asked to approve, among other matters, the Reorganization. On the same date, Via Varejo also published the proposal of Via Varejo's management with respect to the Reorganization for consideration at the extraordinary general meeting of the Via Varejo shareholders.

On September 12, 2016, Via Varejo's shareholders (other than CBD) voted to approve the Reorganization at Via Varejo's extraordinary general meeting of shareholders, with approximately 93.6% of the Via Varejo shareholders in attendance, in person or by proxy, voting in favor of the Reorganization.

Also on September 12, Cnova convened an extraordinary general meeting of shareholders to approve the Reorganization and take certain resolutions in connection with the Transactions.

On October 27, 2016, the extraordinary general meeting of shareholders, with 96.01% of shareholders present or having given proxy, approved the Reorganization with 99.99% of shareholders present or represented voting in favour of the Reorganization. The Reorganization was completed on October 31, 2016.

On December 1, 2016, the Cnova Transaction Committee had a meeting during which it analyzed the fairness opinion of Eight Advisory and decided to recommend the Cnova shareholders who are not affiliated with the Casino Group tender their Shares into the Offers.

*Translation for information purposes only.
In case of discrepancy between the French and the English version, the French version shall prevail.*

This Offer and this draft offer document are subject to the review of the AMF

1.2 Completion of the Reorganization

The steps involved in the completion of the Reorganization are described below, in a non-exhaustive manner.

The organizational structure of Cnova before the Reorganization was the following:

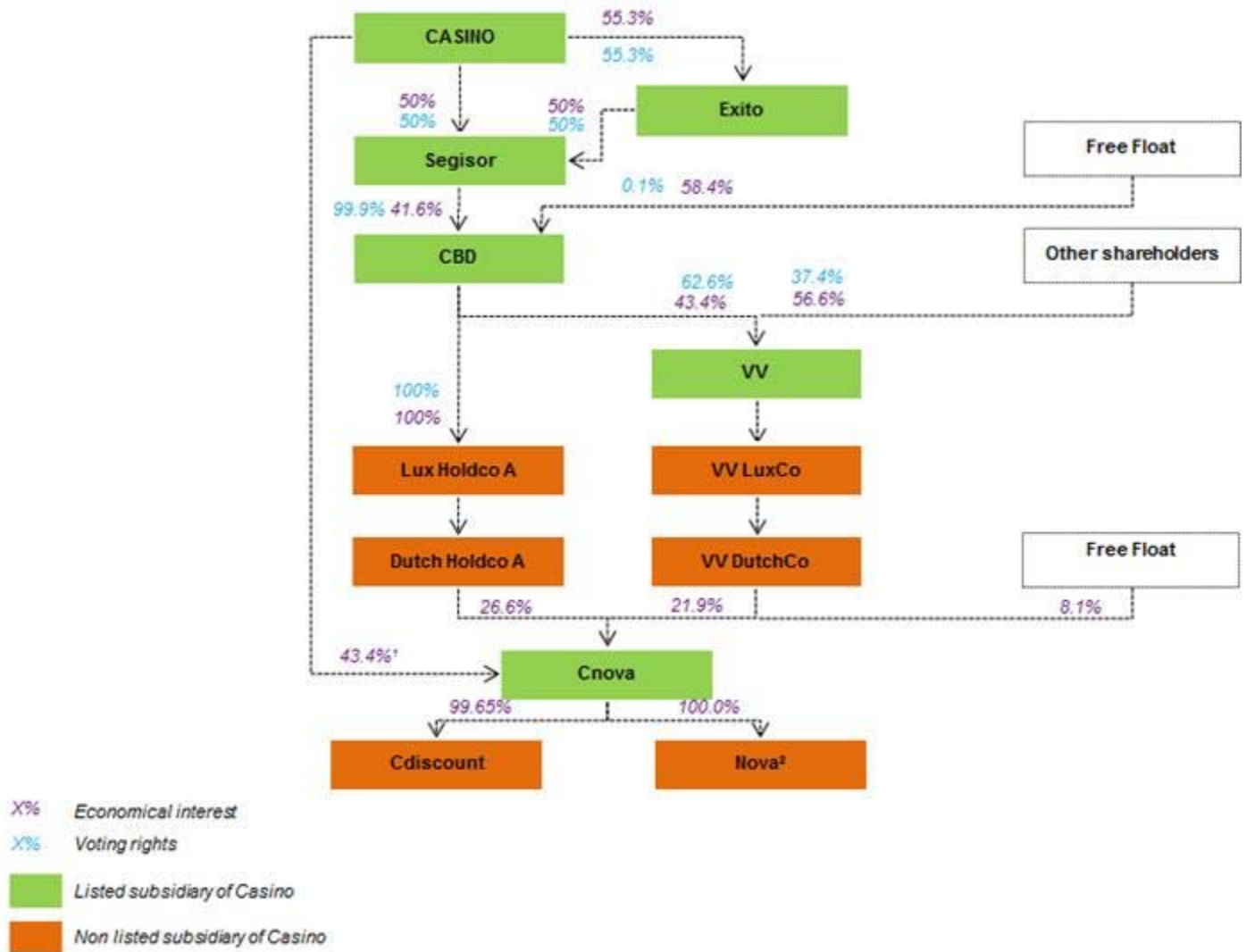

X% Economical interest

X% Voting rights

Green box Listed subsidiary of Casino

Orange box Non listed subsidiary of Casino

¹ Including 0.15% held by Exito

² Cnova Brazil

*Translation for information purposes only.
In case of discrepancy between the French and the English version, the French version shall prevail.*

This Offer and this draft offer document are subject to the review of the AMF

By way of introduction, the general scheme of the Reorganization may be summarized as follows.

- Cnova has granted Via Varejo (indirectly) part of the shares forming Cnova Brazil's share capital through a distribution of these shares for the sole benefit of Via Varejo. This distribution was made possible by the prior conversion of all the 96,790,798 Shares indirectly held by Via Varejo into preferred shares (the "**Distribution Preferred Shares**") which immediately entitled their sole holder to the allocation of a number of shares of Cnova Brazil equal in value to the Shares converted. After this distribution, the Distribution Preferred Shares, having no longer any value, were transferred (indirectly) free of charge by Via Varejo to Cnova for cancellation.
- The remaining shares of Cnova Brazil not distributed to Via Varejo (indirectly) was acquired by Cnova Brazil for a cash payment (the "**Balancing Payment**"), which was provisionally adjusted regarding net indebtedness and working capital requirement of Cnova Brazil on the date of completion of the Reorganization (the "**Balancing Payment Adjustment**") and may be adjusted on the basis of the final accounts. The Balancing Payment thus adjusted represents the difference in value between Cnova Brasil and the Via Varejo's 21.9% interest in Cnova, valued at U.S. \$ 5.00 per Share. These cash amounts are financed by the sums transferred to Cnova Brazil by Via Varejo through a merger that occurred at the beginning of the Reorganization transactions between Cnova Brazil and a subsidiary of Via Varejo, VV Part, the assets of which were composed of cash and securities of companies holding the interest of Via Varejo in Cnova.

Thus, at the completion of the Reorganization, Via Varejo holds the entire capital of Cnova Brazil and no longer holds any stake in Cnova. In the Reorganization, Cnova received:

- The Distribution Preferred Shares, which represented approximately 21.9% of the share capital of Cnova prior to their conversion and which will be canceled on or about January 4, 2017; and
- The Balancing Payment and Adjustment of the provisional compensatory payment for a total amount of R\$ 20,370,301 (i.e. an amount of EUR 5,855,217 at a 3.479 Euro/R\$ rate, without deduction of the taxes remaining to be paid by Cnova), which will be subject to a post-closing adjustment.

In addition, Cnova Brazil has repaid on November 8, 2016 the outstanding loan obligations which it owed to Cnova and Cnova Finança, together with all interest and any other accrued amounts up to the payment date (such principal amount, interest and other accrued amounts are referred herein as to the "**Repayment Amount**"). As of November 8, 2016, the aggregate principal amount and accrued interest owed under such loan agreements was R\$ 526.95 million. As a result of the Reorganization, Via Varejo became the sole shareholder of Cnova Brazil and is no longer a direct or indirect shareholder of Cnova, meaning an amount repay of EUR 145.99 million.

*Translation for information purposes only.
In case of discrepancy between the French and the English version, the French version shall prevail.*

This Offer and this draft offer document are subject to the review of the AMF

These operations are more detailed below.

(i) First step

Via Varejo has contributed to a non-operating holding company, wholly-owned by it, VV Part Participações S.A (hereinafter referred to as “**VV Part**”), in counterpart of the issuance of new shares:

- all of the issued and outstanding shares of Via Varejo Holding S.à.r.l., a wholly-owned subsidiary of Via Varejo organized under the laws of Luxembourg (“**VV LuxCo**”). VV LuxCo holds indirectly through Via Varejo Holding Netherlands B.V., a wholly owned subsidiary of VV LuxCo, organized under the laws of the Netherlands (“**VV DutchCo**”); 96,790,798 Shares, representing the overall holding in Via Varejo in Cnova (i.e. 21.9% of the Shares).
- A cash supplement enabling VV Part to have sufficient equity to (i) enable Cnova Brazil to subsequently pay the Compensatory Payment and the Balancing Payment Adjustment and (ii) to make the subsequent merger between VV Part and Cnova Brazil possible in accounting terms.

Cnova Brazil has then absorbed VV Part by way of merger (hereinafter referred to as the “**VV Part merger**”). Following the merger of VV Part, Cnova Brazil held 100% of the share capital of VV LuxCo and Cnova held a 44.8% stake in Cnova Brazil, the balance being held by Via Varejo.

The following diagram represents the organigram of Cnova at the end of this first step:

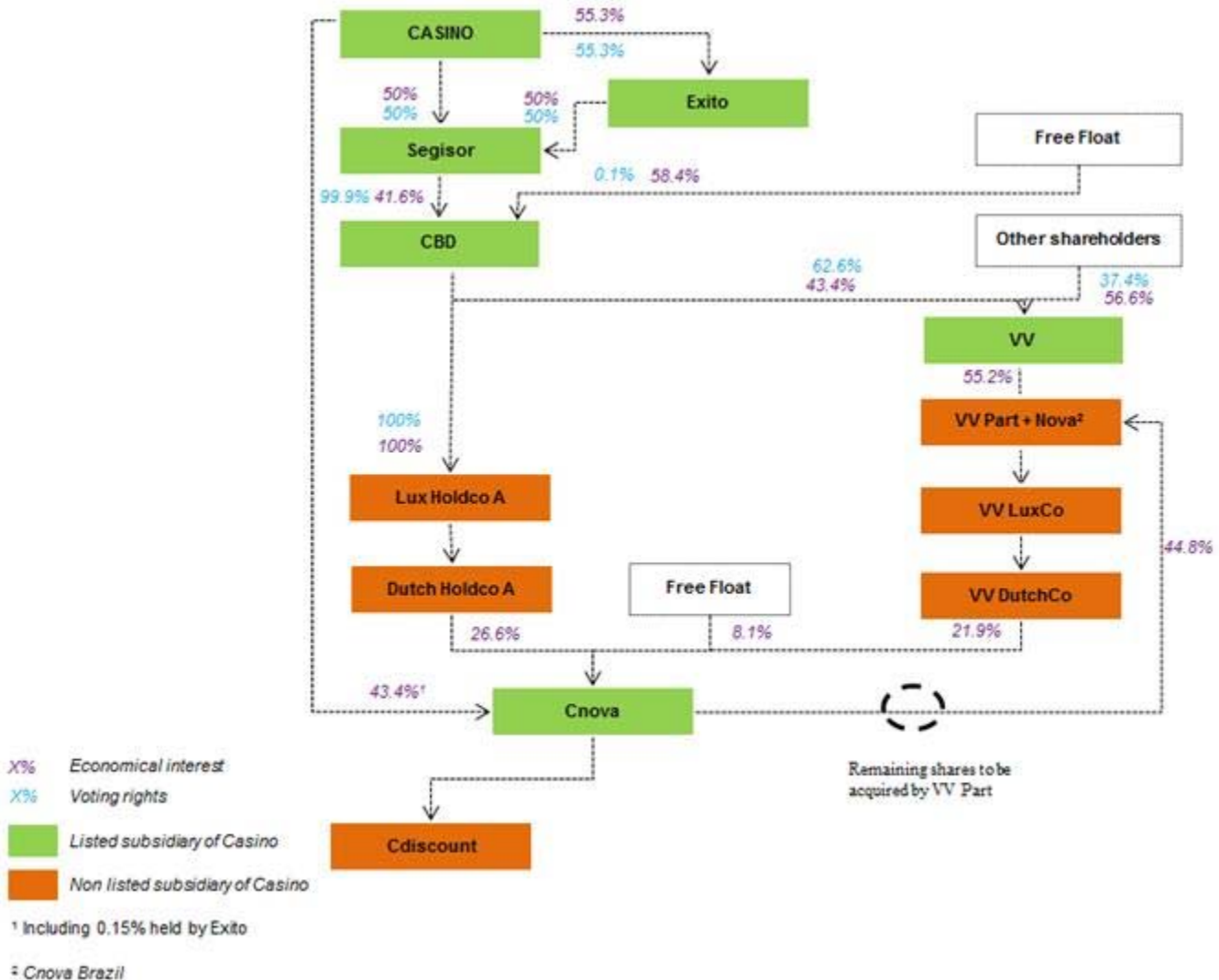

*Translation for information purposes only.
In case of discrepancy between the French and the English version, the French version shall prevail.*

This Offer and this draft offer document are subject to the review of the AMF

(ii) Second step

Cnova has converted its own 96,790,798 Shares (corresponding to 21.9% of its share capital) held by VV DutchCo into special shares which confer the right to an exceptional distribution in kind of Cnova Brazil shares (“**Distribution Preferred Shares**”).

Cnova, has made under the Distribution Preferred Shares, a distribution in kind of 73,974,479 Cnova Brazil shares (out of a total of 74,924,847 shares it held) to VV DutchCo for an amount equal to the actual value of the Shares that have been converted to Distribution Preferred Shares, contractually valued between Cnova and Via Varejo at U.S. \$ 5.00 per share. The Cnova Brazil distributed shares were successively distributed up to Cnova Brazil and have been canceled

Immediately after this distribution, Cnova acquired all the Distribution Preferred Shares free of charges held by VV DutchCo, for the purpose of cancellation.

The following diagram represents the organigram of Cnova at the end of this second step:

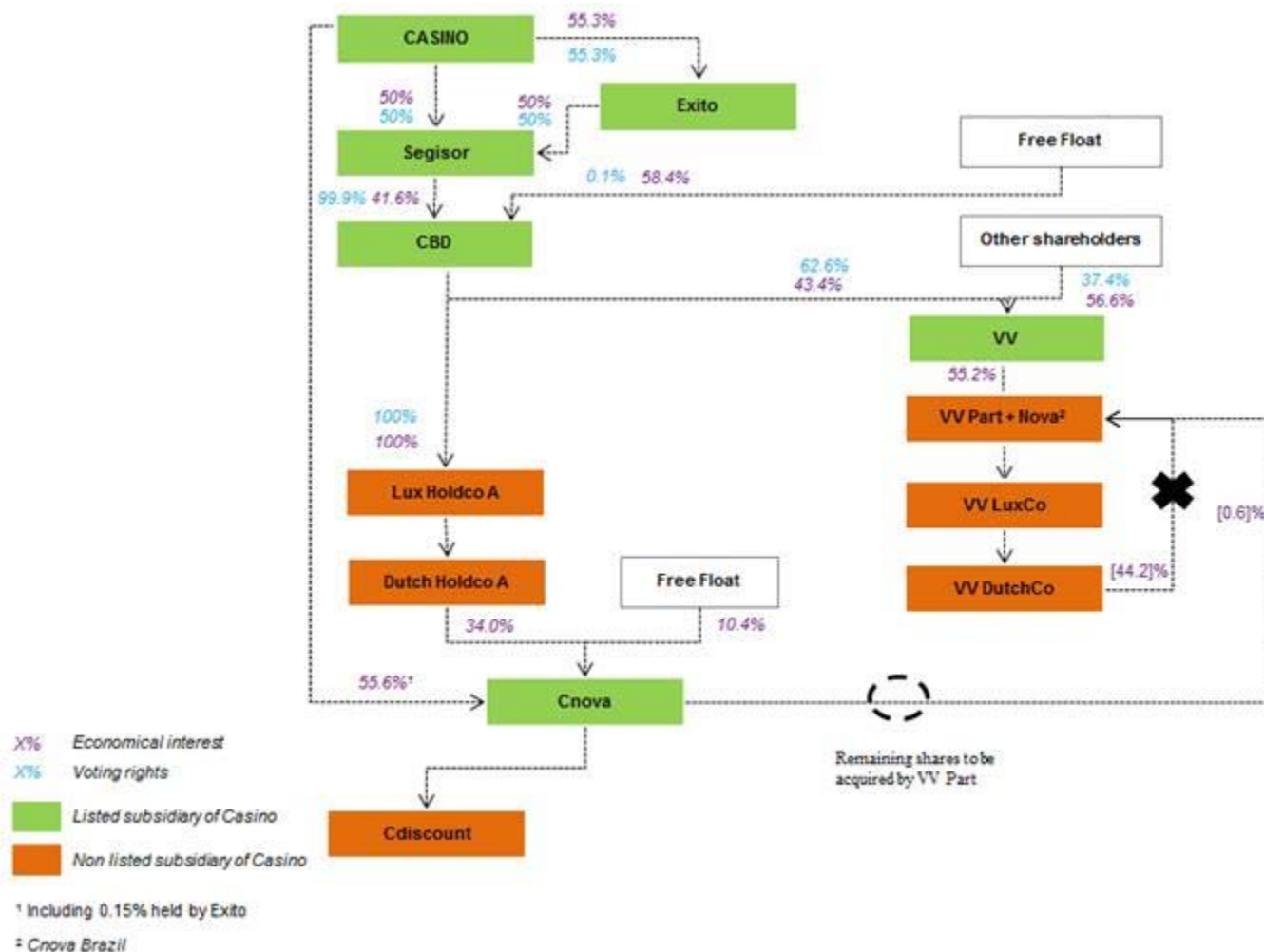

*Translation for information purposes only.
In case of discrepancy between the French and the English version, the French version shall prevail.*

This Offer and this draft offer document are subject to the review of the AMF

(iii) Third step

Immediately thereafter, Cnova sold the remaining Cnova Brazil shares held by it (i.e. 950,368 shares for an aggregate cash payment of approximately R\$ 20.4 million (i.e., approximately € 5.9 million, at a 3.48 Euro/R\$ rate, subject to post-closing adjustments, and without deduction of the taxes remaining to be paid by Cnova) representing the Balancing Payment and the Balancing Payment Adjustment.

Upon completion of the Reorganization, Cnova Brazil has been wholly-owned by Via Varejo (and is expected to be subsequently merged into Via Varejo). In addition, Via Varejo no longer has any direct or indirect interest in Cnova and Cnova no longer has any interest in Cnova Brazil.

The following diagram represents the actual Cnova organigram:

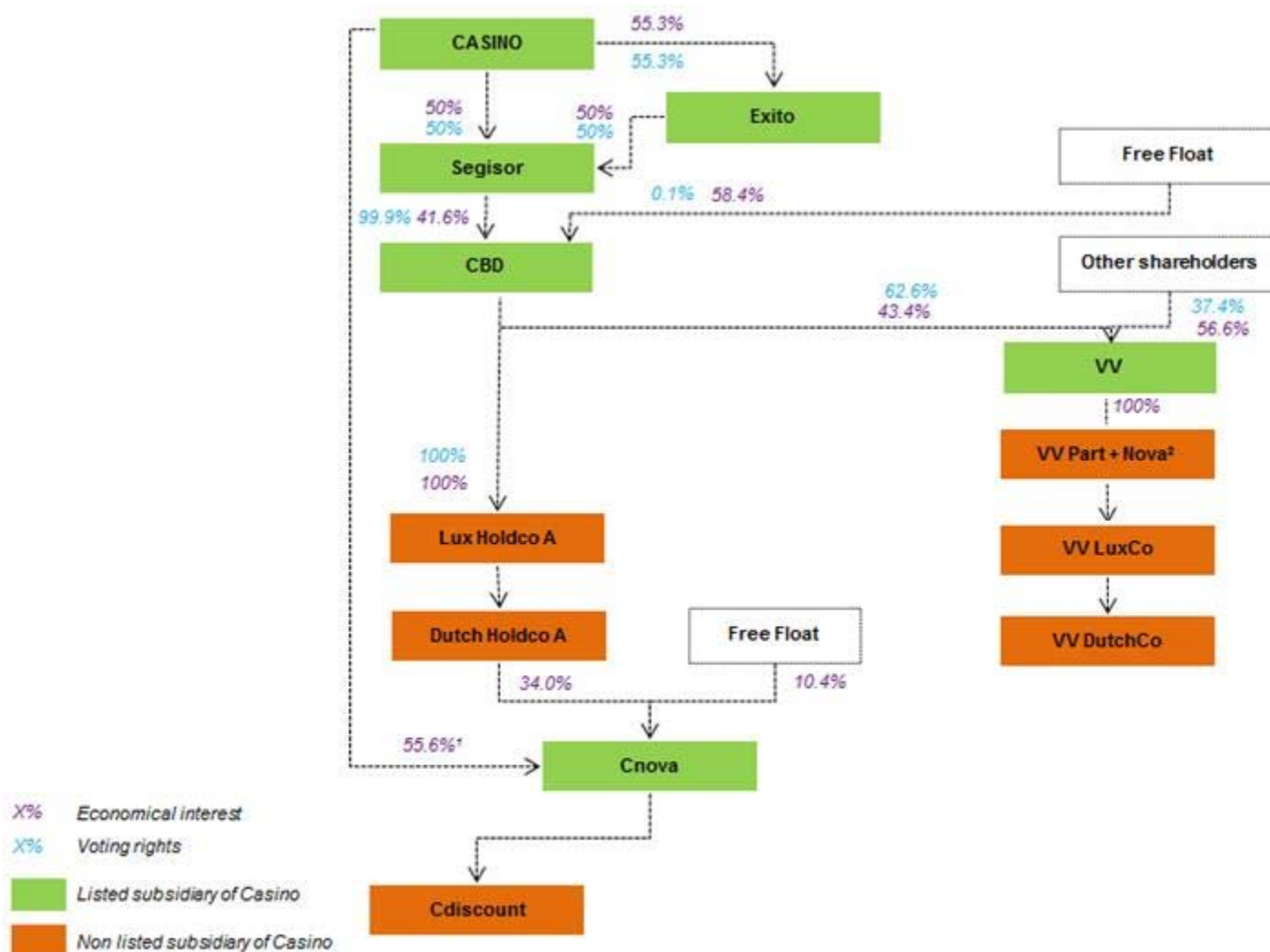

*Translation for information purposes only.
In case of discrepancy between the French and the English version, the French version shall prevail.*

1.3 Transaction agreements

The following describes the principal terms of the agreements that have been entered into in the context of the Transactions, in a non-exhaustive manner.

(i) The Reorganization Agreement

As mentioned in section 1.2, the Reorganization was completed on October 31, 2016. The economic basis of the Reorganization Agreement is described in section 1.2. above.

Balancing Payment Adjustment

Under the Reorganization Agreement, the Balancing Payment was subject to adjustment based on the level of net financial debt and working capital requirements of Cnova Brazil at the closing the Balancing Payment Adjustment). If the (negative) amount of working capital requirements minus the amount of net financial debt of Cnova Brazil at closing exceeded a specified target amount (which is referred to herein as the “**Target Amount**”) by more than 5%, the Balancing Payment was to be adjusted upward by the amount of such excess. Conversely, if the amount of working capital requirements minus the amount of net financial debt of Cnova Brazil at closing was less than the Target Amount by more than 5%, the balancing payment was to be adjusted downward by the amount of such deficit. The target amount depended on the date of the closing, and was based on end-of-month negotiated target levels of Cnova Brazil’s working capital requirements and net financial debt. The global Balancing Payment Adjustment on October 31, 2016 was of R\$3.9 million (on a preliminary basis and subject to the final financial statements).

This amount may be subject to a post-closing adjustment in accordance with the terms of the Reorganization Agreement.

Representations and Warranties

The Reorganization Agreement contains customary representations and warranties of Via Varejo, Cnova and Cnova Brazil that are subject, to specified exceptions and qualifications.

Each of Cnova, Cnova Brazil and Via Varejo made representations and warranties with respect to, among other things:

- organization, good standing and qualification to do business;
- corporate authority and approval relating to the execution, delivery and performance of the Reorganization Agreement;
- the absence of any need for action by governmental authorities in order to complete the mergers, other than actions set forth in the Reorganization Agreement;
- enforceability of the Reorganization Agreement and all other documents necessary to implement the Reorganization;
- absence of proceedings concerning insolvency or bankruptcy; and
- the absence of any conflict with or violation or breach of organizational documents or any conflict with or violation of agreements, laws or regulations as a result of the execution, delivery and performance of the Reorganization Agreement and implementation of the Reorganization.

The Reorganization Agreement also contains additional representations and warranties of Cnova that relate to, among other things:

- ownership of and title to Cnova Brazil shares;

*Translation for information purposes only.
In case of discrepancy between the French and the English version, the French version shall prevail.*

This Offer and this draft offer document are subject to the review of the AMF

- the organization, good standing and qualification to do business of Cnova Brazil and its subsidiaries;
- licenses, records, registrations, permits and consents related to Cnova Brazil's business;
- unaudited financial statements of Cnova Brazil as of June 30, 2016;
- compliance with applicable laws and ongoing litigation;
- conduct of business in the ordinary course by Cnova Brazil between June 30, 2016 and the date of the Reorganization Agreement;
- subsidiaries of Cnova Brazil;
- branches and establishments of Cnova Brazil;
- real estate and other property owned by Cnova Brazil;
- absence of undisclosed liabilities;
- certain contracts of Cnova Brazil and its subsidiaries;
- labor and employment matters at Cnova Brazil;
- employee benefit plans;
- corporate taxes;
- insurance policies at Cnova Brazil;
- guarantees and similar obligations of Cnova Brazil;
- powers of attorney granted by Cnova Brazil and its subsidiaries;
- certain Cnova Brazil intellectual property; and
- certain environmental matters.

Other disposition

Implementation of the Reorganization Steps. Each of Cnova, Cnova Brazil and Via Varejo agreed to carry out, or cause to be carried out, the reorganization steps at the times and on the conditions set forth in the Reorganization Agreement. Cnova has undertaken that Cnova Brazil will not take certain significant decisions until the Reorganization has been completed without the consent of Via Varejo.

Regulatory Approvals. Each of Cnova, Cnova Brazil and Via Varejo agreed to cooperate and proceed with actions required to do whatever was or would have reasonably been expected to be necessary or advisable to obtain any regulatory authorization to implement the Reorganization.

Via Varejo and Cnova Shareholder Meetings. Each of Cnova and Via Varejo agreed to, as soon as reasonably practicable after the date of the Reorganization Agreement: (i) take all actions necessary to duly call and hold a meeting of its respective shareholders for the purpose of adopting the Reorganization Agreement, (ii) include in any shareholders circular required to be prepared a recommendation of the board of directors that its shareholders approve the Reorganization Agreement and (iii) use its reasonable best efforts to obtain necessary shareholder approvals. Each of Via Varejo's and Cnova's shareholders' meeting were held on September 12, 2016 and October 27 2016, respectively.

*Translation for information purposes only.
In case of discrepancy between the French and the English version, the French version shall prevail.*

This Offer and this draft offer document are subject to the review of the AMF

Schedule 13E-3. Among other things, Via Varejo and Cnova agreed to cooperate, and to cause their respective financial advisors to cooperate, in the preparation of a Transaction Statement on Schedule 13E-3, a required disclosure document under U.S. Regulations. Each of Via Varejo and Cnova further agreed to furnish, and to cause their respective financial advisors to furnish, all applicable information concerning Via Varejo or Cnova, as applicable, and their respective subsidiaries, officers, directors, stockholders and affiliates, and to take any other actions, as may be reasonably requested in connection with the foregoing. The Schedule 13E-3 was first filed with the SEC on August 23, 2016 and the most recently amended, as of the date of this Memorandum, on last filing was made on November 1, 2016. The Schedule 13E-3 is available on the website of the U.S. Securities and Exchange Commission (www.sec.gov).

Transfer of Operations and Personnel. Each of the parties to the Reorganization Agreement agreed to cooperate and do whatever was or would have reasonably been expected to be necessary to implement (i) the transfer of the assets and liabilities of Cnova Brazil to Via Varejo and (ii) the transfer of personnel from Cnova Brazil to Via Varejo. Via Varejo has agreed with the treatment of the long term incentive plan benefitting the personnel of Cnova Brazil determined by Cnova's board of directors. Upon completion of the Reorganization, Via Varejo (i) issued to such employees of Cnova Brazil securities replacing the deferred stock units and (ii) entered into amendments to the "cash long term investment plans", in each case as specified in the Reorganization Agreement.

Cnova Finança Restructuring. Prior to the Reorganization Date, Cnova agreed to cause Cnova Brazil to sell and transfer to Cnova all shares of Cnova Finança held by Cnova Brazil so that following the completion of such sale and transfer, Cnova Brazil will no longer have any interest in Cnova Finança. The shares of Cnova Finança held by Cnova Brazil were transferred to Cnova on October 17, 2016.

Indemnification

Indemnification by Cnova. Subject to certain limitations, Cnova agreed to indemnify and hold harmless Via Varejo, its affiliates, Cnova Brazil and any of their respective successors and assigns, which is referred to herein as the "**Via Varejo Indemnified Parties**", from and against any and all losses, damages, penalties, liabilities, costs, charges and expenses, which is referred to herein as "**Losses**", that may be incurred by Via Varejo Indemnified Parties directly or indirectly resulting from:

- any breach or inaccuracy of any representation or warranty made by Cnova;
- any breach of any covenant or any other obligation of Cnova and, prior to October 31, 2016, Cnova Brazil under the Reorganization Agreement;
- the actions, suits, investigations or any proceedings by third persons arising in connection with or related to the accounting practices and employee misconduct relating thereto of Cnova Brazil that were identified by the investigation described in Item 15 of Cnova's Annual Report on Form 20-F filed with the SEC on July 22, 2016, (the "**Cnova Brazil Accounting Investigation**"), provided that Cnova will not be required to indemnify the Via Varejo Indemnified Parties if, and only to the extent that, such Loss is determined by a governmental entity to arise out of or result from a Via Varejo Indemnified Party's former status as a Cnova shareholder;
- the consolidated federal securities lawsuit styled In re Cnova N.V. Securities Litigation, No. 16-cv-444 (LTS) (S.D.N.Y. filed Jan. 20, 2016), as it may be amended from time to time, (the "**Cnova Shareholder Lawsuit**"), provided that Cnova will not be required to indemnify the Via Varejo Indemnified Parties if, and only to the extent that, such Losses are determined by a governmental entity to arise out of or result from a Via Varejo Indemnified Party's former status as a Cnova shareholder;

*Translation for information purposes only.
In case of discrepancy between the French and the English version, the French version shall prevail.*

This Offer and this draft offer document are subject to the review of the AMF

- the Cnova Finança restructuring or any claim arising from facts, acts, events or omissions related to Cnova Finança or the ownership by Cnova Brazil of Cnova Finança, in each case at any time prior to the Reorganization Date;
- the actions, suits or proceedings against Cnova Brazil or any of its subsidiaries (other than Cnova Finança) relating to any claim by any customer of Cnova Brazil or any of its Subsidiaries (other than Cnova Finança) in connection with products sold by Cnova Brazil or any of its subsidiaries (other than Cnova Finança) prior to October 31, 2016, (collectively, the “**Cnova Brazil Consumer Claims**”);
- the actions, suits or proceedings against Cnova Brazil or any of its subsidiaries (other than Cnova Finança) relating to labor, employee or employment claims with respect to any conduct that occurred prior to October 31, 2016, but excluding any such action, suit or proceeding brought by or on behalf of any employee of Cnova Brazil or any of its subsidiaries (other than Cnova Finança) who is terminated by Via Varejo or any of its subsidiaries (including, from and after the Reorganization Date, Cnova Brazil and its subsidiaries (other than Cnova Finança)) upon or following the closing, which is referred to herein, collectively, as “**Cnova Brazil Labor Claims**”; and
- Specified tax matters.

Limitations on Indemnification. Cnova’s indemnification obligations are subject to the following limitations:

- *General Deductible:* The Via Varejo Indemnified Parties are not entitled to indemnification for breaches of representations and warranties (other than certain “**Fundamental Representations**”) or for tax matters unless (and then only to the extent) the aggregate amount of all Losses arising from such claims exceeds approximately R\$25.3 million^[3] and only for the surplus;
- *Consumer Claims Deductible.* The Via Varejo Indemnified Parties are not entitled to indemnification for Cnova Brazil Consumer Claims unless (and then only to the extent) the aggregate amount of all losses arising from such claims exceeds approximately R\$20.5 million^[4] and only for the surplus;
- *Labor Claims Deductible.* The Via Varejo Indemnified Parties are not entitled to indemnification for Cnova Brazil Labor Claims unless (and then only to the extent) the aggregate amount of all losses arising from such claims exceeds approximately R\$22,300^[5] and only for the surplus ;
- *Cap.* Cnova’s indemnification obligations are capped at approximately R\$189.9 million^[6], except with respect to the following matters:
 - Losses arising from breaches of Fundamental Representations and covenants;
 - Losses arising from taxes indemnifiable in connection with the Cnova Brazil Accounting Investigation;

³ Or approximately € 7.11 million on the basis of an exchange rate of BRL 3.554 per 1 euro on 22 November 2016

⁴ Or approximately € 5.77 million on the basis of an exchange rate of BRL 3.554 per 1 euro on 22 November 2016

⁵ Or approximately € 6,275 on the basis of an exchange rate of BRL 3.554 per 1 euro on 22 November 2016

⁶ Or approximately € 53.43 million on the basis of an exchange rate of BRL 3.554 per 1 euro on 22 November 2016

*Translation for information purposes only.
In case of discrepancy between the French and the English version, the French version shall prevail.*

This Offer and this draft offer document are subject to the review of the AMF

- Losses relating to the Cnova Shareholder Lawsuit; and
 - Losses arising from the Cnova Finança restructuring.
- *De Minimis Threshold.* Via Varejo is not entitled to indemnification for breach of a representation or warranty unless the resulting Losses exceeds approximately R\$158,300^[7] (or approximately R\$15,800^[8], in the case of a specified fundamental representation).

Indemnification by Via Varejo. Subject to certain limitations, Via Varejo agreed to indemnify and hold harmless Cnova and its affiliates (other than Via Varejo and its subsidiaries, including Cnova Brazil from and after the Reorganization Date) and any of their respective successors and assigned from and against any and all Losses directly or indirectly resulting from:

- any breach or inaccuracy of any representation or warranty made by Via Varejo; and
- any breach of any obligation of Via Varejo and, from and after the Reorganization Date, Cnova Brazil under the Reorganization Agreement.

Escrow Fund and Optional Guarantees

Escrow Agreement. Promptly following the date of the Reorganization Agreement, Cnova and Via Varejo agreed to negotiate in good faith to agree on the terms of an Escrow Agreement (the “**Escrow Agreement**”), and to enter into the Escrow Agreement prior to the Reorganization Date. The Escrow Agreement was signed on October 31, 2016.

Release of Escrow Funds. The parties agreed to release the amounts contained in the escrow fund from the initial US\$60 million as follows:

- *First anniversary of the Reorganization Date.* On October 31, 2017 all funds, if any, then-remaining in the escrow account in excess of the sum of (i) U.S. \$50.0 million plus (ii) any amounts on account of noticed and pending claims existing as of such date will be released to Cnova. The amounts of any noticed and pending claims referred to in the prior sentence shall be paid to Via Varejo as and when required in accordance with the Reorganization Agreement and Escrow Agreement and after the resolution and payment of any of such claims, any funds remaining in the escrow account in excess of U.S. \$50.0 million that were previously not released on account of such claim will be released to Cnova.
- *Second anniversary of the Reorganization Date.* On October 31, 2018 all funds, if any, then-remaining in the escrow account in excess of the sum of (i) U.S.\$40.0 million plus (ii) any amounts on account of noticed and pending claims existing as of such date will be released to Cnova. The amounts of any noticed and pending claims referred to in the prior sentence shall be paid to Via Varejo as and when required in accordance with the Reorganization Agreement and Escrow Agreement and after the resolution and payment of any of such claims, any funds remaining in the escrow account in excess of U.S. \$40.0 million that were previously not released on account of such claim will be released to Cnova.
- *Sixth anniversary of the Reorganization Date.* On October 31, 2022 all funds, if any, remaining in the escrow account less the aggregate of amount of noticed and pending claims existing as of such date will be released to Cnova. After the resolution and payment of such noticed and pending claims, all funds remaining in the escrow account will be released to Cnova.

⁷ Or approximately €44,538.23 million on the basis of an exchange rate of R\$ 3.554 per EUR 1 on 22 November 2016

⁸ Or approximately € 4.445,38 million on the basis of an exchange rate of R\$ 3.554 per EUR 1 on 22 November 2016

*Translation for information purposes only.
In case of discrepancy between the French and the English version, the French version shall prevail.*

This Offer and this draft offer document are subject to the review of the AMF

Substitution of Guarantee. At any time before October 31, 2022, if Cnova provides a guarantee or letter of credit from a bank or similar financial institution in a mutually agreeable form or a guarantee from Casino in form and substance reasonably acceptable to Via Varejo in an amount equal to the then-remaining funds in the escrow account, the amount of funds, if any, then-remaining in the escrow account will be released to Cnova. Until October 31, 2022, the maximum liability at any time pursuant to such bank guarantee or Casino guarantee will be capped at the amount that would have otherwise been in the escrow account at such time and at the sixth anniversary of the Reorganization Date Cnova and Via Varejo have agreed to take all steps necessary to cause any such guarantee to be of no continuing force or effect.

Good Faith Reevaluation. At the third anniversary of the Reorganization Date, the parties have agreed to discuss in good faith whether, as a result of Cnova's then-current financial position as compared to the expected financial position of Cnova as of immediately following October 31, 2016, the indemnification obligations of Cnova would reasonably be expected to present an unacceptable risk of non-payment, taking into account such matters that the respective boards of directors of Via Varejo and Cnova deem relevant and appropriate. Following such discussions, the parties may agree to release additional funds from escrow or alter the terms of any guarantee then in place.

Governing Law; Dispute Resolution; Specific Performance

Governing Law. The Reorganization Agreement is governed and construed pursuant to the laws of the Federative Republic of Brazil.

Dispute Resolution. Cnova and Via Varejo have agreed to use best efforts to settle any disputes related to the agreement by private negotiation during the 15 days following either party giving notice of a dispute. If resolution is not reached within 15 days, the parties agreed to submit all disputes to confidential and binding arbitration in front of a three arbitrator panel. Each party is entitled to appoint one arbitrator and the party-nominated arbitrators will jointly appoint the third arbitrator. The parties are permitted to seek judicial assistance for the limited purposes of (i) compelling arbitration; (ii) obtaining interim measures of protection rights during the pendency of the arbitral proceedings; and (iii) enforcing any decision of the arbitrators including the final award. The parties agreed that the Courts of the City of São Paulo, Brazil, will have jurisdiction for such purposes.

Specific Performance. Cnova, Cnova Brazil and Via Varejo have agreed that each is entitled to seek specific performance of the Reorganization Agreement in accordance with the Brazilian Code of Civil Procedure, without prejudice to reimbursement for losses and damages incurred by the enforcing party as a result of the other party's failure to perform.

(ii) New Operational Agreement

In connection with the execution of the Reorganization Agreement, CBD and Via Varejo entered into a new operational agreement, that became effective upon completion of the Reorganization, establishing the terms and conditions for the commercial and strategic alignment of their retail and eCommerce activities, in particular with respect to joint acquisitions of common products and eCommerce activities under the brand “**Extra**”. Also upon completion of the Reorganization, the existing operational agreement among CBD, Via Varejo, Cnova Brazil and Cnova will be terminated. The existing operational agreement among CBD, Via Varejo, Cnova Brazil and Cnova is described under Item 7.B. of Cnova's Annual Report on Form 20-F for the year ended December 31, 2015, filed with the SEC on July 22, 2016.

*Translation for information purposes only.
In case of discrepancy between the French and the English version, the French version shall prevail.*

This Offer and this draft offer document are subject to the review of the AMF

(iii) The Casino-Cnova Undertakings Letter

In connection with the Reorganization, Casino and the Cnova Transaction Committee entered into the Casino-Cnova Undertakings Letter, pursuant to which Casino agreed to launch the Offers promptly following the completion of the Reorganization. The following describes the material provisions of the Casino-Cnova Undertakings Letter. The summary does not purport to be complete and may not contain all of the information about the Casino-Cnova Undertakings Letter that may be important to Cnova shareholders.

Casino Undertakings. Pursuant to the Casino-Cnova Undertakings Letter, subject to (i) the completion of the Reorganization and (ii) the Cnova board of directors and/or Transaction Committee supporting the Offers and rendering, on or prior to the execution of the Reorganization Agreement, a positive opinion and position statement with respect to the Offers, and immediately prior to the filing of the French Offer with the AMF, confirming their positive reasoned opinion in view of an independent expert's fairness opinion, Casino has agreed to do the following, among other things:

- *Offers commitment.* Launch the Offers promptly upon completion of the Reorganization for any and all Shares at a price of U.S. \$5.50 (with respect to the U.S. Offer) and an equivalent amount in euros with respect to the French Offer;
- *Support of the Combination.* Vote in favor of the Reorganization at Cnova's extraordinary general meeting of shareholders, in its capacity as a Cnova shareholder; and
 - *Stock Appreciation Rights.* Authorize, in accordance with the terms of the Stock Appreciation Rights (SAR) granted in November 2014 by Casino to certain employees of Cnova who will be transferred to Via Varejo on the basis of the Reorganization, the adjustment of the terms of said SAR proposed by the Cnova Transaction Committee as described in paragraph 2.2.4 of this draft offer memorandum.

Casino has no right to terminate its undertakings unless if Cnova issues or resolves or commits to issue additional Shares, prior to launch of the Offers.

(iv) The Casino and CBD Letters

In connection with the Reorganization, Casino and CBD made certain undertakings to each other pursuant to a letter agreement from CBD to Casino, dated August 8, 2016, (the "**CBD Support Letter**"), and a letter agreement addressed to the CBD independent committee and executed by Casino and CBD, dated August 8, 2016, (the "**Casino-CBD Commitment Letter**"). The CBD Support Letter and the Casino-CBD Commitment Letter are intended to govern the parties' ongoing relationship to each other in their capacity as shareholders of Cnova following completion of the Reorganization and the Offers.

The following describes the material provisions of the Casino-CBD Commitment Letter and the CBD Support Letter. The summary does not purport to be complete and may not contain all of the information about the CBD Support Letter and the Casino-CBD Commitment Letter that may be important to Cnova shareholders.

*Translation for information purposes only.
In case of discrepancy between the French and the English version, the French version shall prevail.*

This Offer and this draft offer document are subject to the review of the AMF

CBD Support Letter

Pursuant to the CBD Support Letter, signed on August 8, 2016, CBD informed Casino that at the meeting held on August 8, 2016 the CBD board of directors unanimously resolved (i) to cause its voting rights to be exercised at any Cnova shareholders meeting in favor of the Reorganization, (ii) not to tender the 177,303,664 Shares it indirectly holds (the “**Subject Shares**”) directly or indirectly into the Offers, nor otherwise dispose of or transfer the Subject Shares in any other manner or through any other instrument, including any derivative instruments until completion of the Offers. CBD further agreed to stand alongside and cooperate with Casino in subsequent Squeeze-Out proceedings, if any, following completion of the Offers.

Casino-CBD Commitment Letter

CBD Undertakings. In the event that CBD decides to sell any of the Subject Shares to a third party, CBD undertakes to (i) first offer the Subject Shares to Casino at the price offered by the third party and (ii) if Casino do not wish to buy the Subject Shares or if Casino and CBD do not reach an agreement on the purchase price of the Subject Shares, to impose on the proposed buyer to acquire up to the same proportion of Cnova shares held by Casino, more or less simultaneously and under the same conditions.

Casino Undertakings. In consideration for CBD undertaking not to tender its Shares to Cnova to the Offers, Casino has taken the following undertakings which became enforceable upon completion of the Reorganization

- *Director Designation Rights.* Casino will ensure that CBD has the right to designate at least one member to the Cnova board of directors so that the ratio of (i) non-independent members of the Cnova board of directors appointed by CBD *divided by* (ii) the total number of non-independent directors is at least equal to CBD’s economic interest in Cnova’s outstanding Shares (such director or directors, the “**CBD Directors**”);
- *Information Rights.* Casino will ensure that CBD and/or the CBD Directors have access to the following information with respect to Cnova: (i) audited statutory and consolidated accounts, (ii) annual budget and forecast, (iii) half-year and quarterly accounts, (iv) annual report, (v) details of any material change in business, financial position or affairs and (vi) any other information that may be required for CBD to comply with Brazilian capital markets regulations. Casino also agreed to cause Cnova to make members of Cnova’s senior management reasonably available to CBD or the CBD Directors;
- *Good Faith Consideration of an IPO.* If, as a result of the Offers, Shares are no longer listed on the NASDAQ or Euronext Paris, Casino has agreed to consider in good faith the opportunity to launch, in due time and depending on Cnova’s then-current strategic and financial objectives and then-prevailing market conditions, an initial public offering of Cnova or, as the case may be, any subsidiary thereof, which is referred to herein as an “**IPO**”;
- *Good Faith Consideration of a Fully Marketed Offering.* If, following the Offers, Shares continue to be listed on the NASDAQ or Euronext Paris, Casino agreed to consider in good faith the opportunity to launch a fully marketed offering, which is referred to herein as an “**FMO**”, through the sale of a significant portion of Shares, aimed at increasing the free float and liquidity of Shares;

*Translation for information purposes only.
In case of discrepancy between the French and the English version, the French version shall prevail.*

This Offer and this draft offer document are subject to the review of the AMF

- ***IPO or FMO Assessment Right.*** CBD may require Casino to engage a first-tier advising bank selected by Casino to assess in good faith the opportunity of an IPO or an FMO and in both cases the opportunity and feasibility of a secondary placement (*i.e.*, through the sale of existing Shares). CBD may not exercise such right only two years after the signing of the CBD – Casino Commitment Letter and then no more than once in any two year period;
- ***IPO and FMO Priority.*** If Casino or Cnova decides to initiate an IPO or FMO (including any secondary offering), CBD has the right to sell all of its shares as part of such offering, with priority over Casino with respect to up to 90% of the total Shares to be offered in such secondary offering, subject to certain exceptions;
- ***Tag Along Rights (Change-in-Control Transaction).*** Casino has agreed that, if it intends to transfer any or all of its Shares to any third party (except for sales among members of the Casino Group or the controlling affiliates of Casino), which transfer will constitute a change-in-control of Cnova, CBD will be entitled to require the transferee to acquire all of its shares in Cnova at approximately the same time and on the same conditions;
- ***Tag Along Rights (Not a Change-in-Control Transaction).*** Casino agreed that if it intends to transfer any or all of its Shares to any third party (except for sales among members of the Casino Group or the controlling affiliates of Casino), which transfer will not constitute a change-in-control of Cnova, CBD will be entitled to require the transferee to acquire up to the same portion of the Subject Shares at approximately the same time and on the same conditions; and
- ***Survival of Rights.*** In the case of any reorganization or other corporate transaction involving Cnova resulting in an exchange, redemption or allotment of Shares (other than in a transaction where CBD would have the right to sell all of its Shares on the same conditions as Casino), Casino has agreed to ensure that CBD keeps the rights granted or receives rights similar to those granted by the Casino-CBD Commitment Letter with respect to the surviving entity.

The undertakings of Casino and CBD in the Casino-CBD Commitment Letter survive until the earliest of (i) the day when Casino no longer controls, directly or indirectly, Cnova, (ii) the day when CBD is no longer a shareholder of Cnova and (iii) August 8, 2041.

2. PRESENTATION OF THE OFFER

[7] Or approximately €44,538.23 million on the basis of an exchange rate of R\$ 3.554 per EUR 1 on 22 November 2016

[8] Or approximately € 4.445,38 million on the basis of an exchange rate of R\$ 3.554 per EUR 1 on 22 November 2016

2.1 Capital and voting rights of Cnova repartition

In connection with its initial public offering in November 2014, Cnova has implemented a special voting structure (the “**Double Voting Right Structure**”) that allowed a limited number of founding shareholders (including Casino, CBD, Via Varejo, Exito and holding companies controlled by certain current and former managers of Cnova Brazil, collectively, the “**Founding Shareholders**”) to receive a second voting right for the Shares held by them at the time of the IPO so long as such Shares remaining registered in their name in a securities register maintained by Cnova (the “**Qualifying Shares**”). For this purpose, Stichting Cnova Special Voting Shares (the “**Voting Foundation**”), was been incorporated to serve as a voting depository. Cnova issued to the benefit of the Voting Foundation (without consideration) a number of special voting shares (each bearing a voting right but effectively no right to dividend) equal to the number of Qualifying Shares. Symmetrically, the Voting Foundation has issued special voting depository receipts (the “**Depositary Receipts**”) to each Founding Shareholder in respect of the special voting shares held by the Voting Foundation. Thus, each Founding Shareholder received a number of Depositary Receipts equal to the number of Qualifying Shares it held. The Depositary Receipts entitle the relevant Founding Shareholders to obtain, before each meeting of Cnova shareholders, a voting proxy from the voting depository that permits the Founding Shareholders to vote the special voting shares represented by their Depositary Receipts at such general meeting (in person or by proxy), or to instruct the Voting Foundation to vote such special voting shares at the meeting on behalf of the Founding Shareholder, in each case, pursuant to the relevant terms of the Double Voting Right Structure. Founding Shareholders who decide to sell all or part of their Qualifying Shares or to deregister them (in order to have them registered in a clearing system for instance) lose the Depositary Receipts corresponding to such Qualifying Shares and the underlying special voting shares held by the Voting Foundation are transferred without consideration to Cnova. Only in limited cases, such as the transfer of Qualifying Shares by a Founding Shareholder to a transferee at least 90%-controlled by it, can the transferee receive Depositary Receipts with respect to the transferred Qualifying Shares, subject to certain relevant terms of the Double Voting Right Structure. Further, shares acquired by Founding Shareholders do not entitle them to receive new Depositary Receipts except in the case of shares subscribed as part of a capital increase – in which case Cnova would issue new special voting shares to the Voting Foundation. Except under the limited circumstances described above, the Founding Shareholders cannot dispose of their Depositary Receipts and the Voting Foundation cannot dispose of its special

voting shares except when it transfers them to Cnova. There is special voting depositary receipts in respect of special voting shares held by Cnova itself.

*Translation for information purposes only.
In case of discrepancy between the French and the English version, the French version shall prevail.*

This Offer and this draft offer document are subject to the review of the AMF

As a result of the Reorganization, the Depositary Receipts held by Via Varejo were cancelled and the Voting Foundation transferred 96,790,798 special voting shares to Cnova for no consideration. At the Cnova EGM on October 27, 2016, Cnova shareholders resolved to cancel the 96,760,798 special voting shares. The cancellation should take effect on or around January 4, 2017.

As of the date of this draft offer memorandum, 314,940,097 special voting shares in the capital of Cnova are issued and outstanding, all being owned by the Voting Foundation, in respect of which the Voting Foundation has issued 314,940,097 special voting depositary receipts to the persons shown below.

The following table presents, to the knowledge of the Offeror, as of the date hereof the capital and voting rights of the Company following the completion of the Reorganization.

Shareholders	Number of Shares	% of Share Capital	Number of Special Voting Depositary Receipts	Number of Special Voting Shares	% of Voting Rights
Casino, Guichard-Perrachon	190,974,069	55.4340%	190,974,069	0	57.9194%
Almacenes Exito S.A. ^[9]	659,383	0.1914%	659,383	0	0.2000%
Companhia Brasileira de Distribuicao Netherlands Holding B.V. ^[10]	117,303,664	34.0497%	117,303,664	0	35.5764%
<i>SUB-TOTAL CASINO GROUP</i>	<i>308,937,116</i>	<i>89.6751%</i>	<i>308,937,116</i>		<i>93.6958%</i>
Euris S.A. ^[11]	2,500,000	0.7257%	0	0	0.3791%
Board members	147,767 ^[12]	0.0004%	0	0	0.0224%
Other holders of bearer shares	26,535,127	7.7023%	0	0	4.0224%
<i>SUB-TOTAL FREE FLOAT</i>	<i>29,182,894</i>	<i>8.4709%</i>	<i>0</i>	<i>0</i>	<i>4.4254%</i>
QE Participações Ltda.	6,002,981	1.7425%	6,002,981	0	1.8206%
Other registered shareholders	384,057	0.1115%	0	0	0.0582%
<i>SUB-TOTAL REGISTERED SHAREHOLDERS</i>	<i>6,387,038</i>	<i>1.8540%</i>	<i>6,002,981</i>		<i>1.8788%</i>
Stichting Cnova Special Voting Shares	0	0%	0	314 940 097	0%
TOTAL	344,507,048	100%	314,940,097	314,940,097	100%
<i>For information purposes : Treasury shares being canceled</i> ^[13]	96,790,798			97,174,855	

⁹ Exito is a subsidiary of Casino on which Casino has exclusive control. Exito has informed Casino that it will not tender its shares to the Offer and Casino will take all the necessary measures to promote its contractual and statutory rights so that Exito will not tender its Shares into the Offer.

¹⁰ Companhia Brasileira de Distribuicao Netherlands Holding B.V. is a holding company wholly owned by Companhia Brasileira de Distribuicao (CBD), a subsidiary of Casino on which Casino has exclusive control directly and via Exito. CBD has undertaken not to tender its shares to the Offer and Casino will take all the necessary measures to promote its contractual and statutory rights so that CBD will not tender its Shares into the Offer.

¹¹ Being specified that Mr Jean-Charles Naouri controls Casino notably through a company, Euris, that indirectly controls Casino, and has indicated its intention to tender its shares to the Offer.

¹² Of which 122 200 Shares and 25 567 RS.

¹³ 97,174,855 special voting shares and 96,790,798 Distributing Preferred Shares held by Cnova as a result of the Reorganization for the sole purpose of being canceled. This cancellation is expected to take place around January 4, 2017.

*Translation for information purposes only.
In case of discrepancy between the French and the English version, the French version shall prevail.*

This Offer and this draft offer document are subject to the review of the AMF

Subject to the Shares held by Cnova within the Reorganization and being cancelled, Casino and its subsidiaries Exito and CBD, as well as the holding company Euris, a French simplified joint-stock company (*société par actions simplifiée*) with a capital of € 164,806, whose registered office is at 83, rue du Faubourg Saint-Honoré in Paris (75008), registered with the Paris Trade and Companies Register under number 348,847,062 (“**Euris**” which indirectly controls Casino) and Mr. Jean-Charles Naouri (Chairman and CEO of Casino), did not acquire directly or indirectly any Share during the 12 months preceding the filing of the Offer on December 6, 2016, and had neither entered into an agreement nor acquired an instrument enabling them to acquire Cnova shares at their sole discretion.

2.2 Intentions of the Offeror for the coming twelve months

2.2.1 Strategic rationale and future activity

As required by Cnova Transaction Committee during its review of the projected Reorganization, Casino, as the controlling shareholder of Cnova, decided to launch the Offers after completion of the Reorganization.

On May 11, 2016, after deliberation, Casino board unanimously approved, the Reorganization and, under the provisions of Article L. 225-38 of the Commercial Code, unanimously authorizes the launch of a public tender offer on the Shares held by Cnova’s minority shareholders at a price of U.S. \$ 5.50 per Share, subject to the fulfilment of the conditions precedent set out in the Casino-Cnova Undertakings Letter (as described in section 1.3 of this draft offer memorandum) which have been fully performed since.

Intentions and motives of the Offeror regarding the Reorganization

In the context of the appreciation of the Reorganization prior to the Offers Casino believed that the Reorganization would generate operational and financial efficiencies at both Cnova and Via Varejo that will put each company, by combining their respective resources, in stronger operational and competitive positions. The Offers will not generate synergies independently from the Reorganization. The synergies taken into account by Casino in its consideration of the Reorganization which were determined with the assistance of a third-party strategic advisor, reflect an estimate of all synergies between Via Varejo and Cnova Brazil that are achievable within three years following consummation of the Reorganization. Those synergies reflect both potential cost decreases resulting from integration and consolidation of Via Varejo and Cnova Brazil operations and sales increases resulting from the implementation of a full multi-channel strategy, which accrue to the benefit of Via Varejo.

Regarding Cnova, which will continue its activity through its subsidiary Cdiscount in France, Casino believes that the Transactions will result in an increase of the value of its investment in the Company by, among other things, allowing it to focus on the French market, better performing than the Brazilian market, simplify its governance structure and reducing related administrative burdens, and increase the ability of its management to execute effectively its future strategic plans.

Casino believes that the Transactions will, among other things, maximize the value of its investment in Via Varejo by, among other things, enabling Via Varejo to realize greater economies of scale, increasing Via Varejo’s purchasing and negotiating power with respect to third-party suppliers and contractors, generating operational synergies from the integration of Cnova Brazil’s eCommerce retail and delivery operations into Via Varejo’s existing and expansive Brazilian operating footprint, generating multi-channel advertising and marketing opportunities and permitting Via Varejo to market its existing products on Cnova Brazil’s eCommerce platform on more favorable terms.

*Translation for information purposes only.
In case of discrepancy between the French and the English version, the French version shall prevail.*

This Offer and this draft offer document are subject to the review of the AMF

Intentions and motives of the Offeror about the Offers

As a controlling shareholder of Cnova, Casino's primary purpose in supporting the Transactions, and in committing to launch the Offers pursuant to its Undertakings Letter towards Cnova, is to maximize the value of its investment in Cnova and to offer an opportunity for an immediate liquidity to Cnova's minority shareholders that do not wish to remain shareholders of the Company now that the transfer of Cnova Brazil to Via Varejo has been completed, at a price that would be considered fair by the Cnova Transaction Committee.

Additionally, Casino believes that the Offer is in the interest of Cnova's minority shareholders. The Offer Price offered by Casino in the Offer reflects:

- a premium of 80.6 % over the closing price for Shares on Euronext Paris on April 27, 2016, the trading day immediately prior to first public reports regarding the Reorganization, which is referred to herein as the "**Unaffected Cnova Share Price**"; and
- a premium of 73.1 % over the closing price for Shares on Euronext Paris on May 11, 2016, the day immediately preceding the announcement of entry into a non-binding memorandum of understanding with respect to the Reorganization and to the announcement of a tender offer;
- a premium of 100.5% over the volume-weighted average of the last 60 stock exchange prices on Euronext Paris before May 12, 2016, the day immediately preceding announcement of entry into a non-binding memorandum of understanding with respect to the Transactions.

2.2.2 Composition of the Cnova's Board

Following completion of the Reorganization, Mr. Esterman, the current CEO of Via Varejo and formerly the Chairman of the Cnova Board, resigned from his positions on the Cnova Board. The Cnova's Board is now composed as follows:

- Antoine Giscard d'Estaing (appointed Chairman on November 17, 2016)
- Didier Lévêque, Vice Chairman,
- Ronaldo Iabrudi dos Santos Pereira, Vice Chairman
- Eleazar de Carvalho Filho
- Silvio J. Genesini
- Bernard Oppetit
- Arnaud Strasser
- Emmanuel Grenier
- Yves Desjacques

*Translation for information purposes only.
In case of discrepancy between the French and the English version, the French version shall prevail.*

This Offer and this draft offer document are subject to the review of the AMF

Casino and its subsidiary CBD intend to nominate, during the next General Meeting, convened for January 13, 2017, a representative of CBD, Mr Christophe José Hidalgo, as a board member, in accordance with the Casino-CBD Commitment Letter, so that the commitments under this letter in terms of governance are respected. On the occasion of this general meeting, Mr Didier Lévêque will resign from his functions as board member.

2.2.3 Intentions regarding employment and management

The Offeror considers that a key element of the success of Cnova is preserving and developing the talent and intellectual capital of Cnova's personnel. In this context, the Offeror does not have any plan to modify Cnova's current strategy regarding staffing, having specified that the employees of Cnova Brazil have been transferred to Via Varejo as part of the Reorganization.

The Offer will not impact significantly employment at the level of Cnova group.

2.2.4 Situation of LTI beneficiaries

Cnova has adopted an incentive plan call "Long Term Incentive Plan" under which Cnova has issued DSUs and Casino has issued some "Stocks Appreciation Rights" ("**SAR**")¹⁴ (the "**Omnibus Incentive Plan**") to give the Company a competitive advantage in attracting, retaining and motivating selected directors, officers, employees and consultants of Cnova and its subsidiaries and affiliates, and to provide incentives for future performance of services directly linked to shareholder value. Cnova also adopted, in relation to the issuance of DSUs, a qualified sub-plan of the Cnova NV 2014 Omnibus Incentive Plan for the benefit of certain French beneficiaries (the "*Sous-Plan Qualifié Français*").

With regards of the DSU no Share will be issued during the Offer, except in the event of the death of a French recipient, in which case the Shares underlying the DSU may be transferred to the heirs of the deceased person who may transfer them. The DSU cannot be transferred by its recipients.

It is recalled that the SARs do not give a right to the issuance of Shares of the Company but to the payment, at the vesting date (November 2018) and under certain conditions, to an amount in cash.

Due to the Reorganization, Via Varejo has issued to the benefit of three beneficiaries transferred to Via Varejo, in replacement of their DSU, options to subscribe shares for an equivalent value as to the August 8, 2016 value. For those same beneficiaries, Cnova has adjusted the terms of the SAR in order to provide equivalent value in Via Varejo units to the SARs benefitting such individuals as of August 8, 2016 (assuming a Cnova share value of U.S. \$5.00, identical to the value used in the Reorganization Agreement, for purposes of the SAR adjustment).

At the exception of those particular cases, the Offers will not impact the DSU, RSU and SAR held by the current employees of Cnova and former employees of Cnova. However, if the Offers are followed by a Squeeze-Out, or a delisting of the Shares, or a material decrease in liquidity of Shares, the Cnova's Board will contemplate adjustments to the DSU and RSU plans in order to take into account the resulting illiquidity.

¹⁴ The SARs are borne by Casino, but in accordance with IFRS, their cost is recorded as an expense in the Cnova financial statements.

*Translation for information purposes only.
In case of discrepancy between the French and the English version, the French version shall prevail.*

This Offer and this draft offer document are subject to the review of the AMF

In addition, under the Cnova NV 2014 Omnibus Incentive Plan, the Cnova Board approved on October 30 2014, the allocation of 25,567 Shares to certain of its board members, which are, until the end of an acquisition period, subject to transfer restrictions, the RS. Of the RS initially issued, 8,523 have not yet been definitively acquired by their beneficiaries and, therefore, not transferable by the end of the Offer period. Nevertheless, the Offer targets all the RS.

2.2.5 Dividend distribution policy

Since its incorporation, Cnova has never paid any dividend. The distribution policy will be examined subsequently, in relation notably to Cnova's results, its financial capacity for such distribution and its financing needs in view of its development plans.

2.2.6 Perspective regarding possible merger

Casino does not intend to merge with Cnova but reserves its right to support as a shareholder any restructuring transaction affecting Cnova.

2.2.7 Liquidity

The purchase of Shares by Casino pursuant to the Offers will reduce the number of shareholders, as well as the number of Shares trading publicly. As a result, the liquidity and market value of the Shares that were not tendered into the Offer may be adversely affected. Casino does not intend to compensate such adverse effect by, for example, setting up a liquidity mechanism for the Shares that are not tendered.

2.2.8 Squeeze-out (retrait obligatoire)

If, following the completion of the Offers, Casino and its affiliated companies (including CBD and Exito) own 95% or more of the issued and outstanding ordinary share capital (*geplaatst en uitstaand gewoon kapitaal*) of Cnova, then Casino, acting on its own or with its group companies (including CBD and Exito), would have the right, but not the obligation, to initiate a Buy-Out procedure (*uitkoopprocedure*) in accordance with Article 2:92a or 2:201a of the Dutch Civil Code and/or a Takeover Buy-Out procedure in accordance with Article 2:359c of the Dutch Civil Code, in order to acquire the remaining Shares not tendered in the Offers and not held by Casino and its group companies or Cnova. In such procedure, should it happen, the competent Dutch court will determine the fair price to be paid for the Shares of any remaining minority shareholders of Cnova. This fair price per share will typically be equal to the consideration per share offered in the Offers (if this price has been considered fair by the independent expert) unless there would be financial, business or other developments or circumstances that would justify a different price (including a reduction resulting from the payment of dividends or a higher price) in accordance with, respectively, Article 2:92a, paragraph 5 or 2:201a, paragraph 5 or Article 2:359c, paragraph 6 of the Dutch Civil Code. Similarly, if, following the completion of the Offers, Casino and its group companies own 95% or more of the issued and outstanding ordinary share capital (*geplaatst en uitstaand gewoon kapitaal*) of Cnova and 95% or more of the voting interests in Cnova, any minority shareholder would have the right, but not the obligation, to institute a court procedure pursuant to Article 2:359d of the Dutch Civil Code to require Casino to purchase its Shares against a fair price to be determined by the competent Dutch court, as described above. A minority shareholder would have to file such claim with the competent Dutch court within three months after the end of the acceptance period of the Offers.

*Translation for information purposes only.
In case of discrepancy between the French and the English version, the French version shall prevail.*

This Offer and this draft offer document are subject to the review of the AMF

2.2.9 Delisting following a Buy-Out

Euronext Paris would have to be informed in advance of the Statutory Buy-Out procedure before the Enterprise Courts in order to determine the practical date on which the delisting would occur (as Euronext Paris is mainly used to the automatic delisting procedure after a Statutory Buy-Out regulated by French laws and AMF regulations).

Once the judgement has been rendered, Euronext would issue a market notice informing the market of the delisting (radiation) date. This date would correspond to the date when the Shares owned by minority shareholders will be transferred to Casino as a result of the judgement of the Enterprise Court.

The notice would inform shareholders and custodians about (i) the technicalities of the Statutory Buy-Out, (ii) the indemnification paid to the shareholders, (iii) the technicalities of the payment and (iv) who will be the custodian of the indemnification for unidentified shareholders.

2.2.10. Delisting aside from a Statutory Buy-Out

It is reminded that, pursuant to Articles 6905/1 et seq. of the Euronext Harmonized Market Rules, Euronext Paris may cancel the securities admitted to its markets at the issuer's written request stating the reasons for its request. Euronext Paris is only able to accept such a request if the liquidity of the shares is greatly reduced at the end of the Offer and the delisting is not contrary to the interest of the market and comply with the Euronext market rules. Euronext Paris could thus decide not to proceed with the delisting of shares as requested by an issuer if such a delisting should prejudice the fair, orderly and efficient functioning of the market. Euronext Paris may also make a delisting of the securities subject to any additional conditions it deems appropriate.

Furthermore, in the event that it would not be in a position to implement the Statutory Buy-Out, the Offeror reserves the right to ask Euronext Paris for the delisting of the Shares of the Euronext Paris market. Such delisting could take place under the conditions set out in Article P. 1.4.2 of Livre II of the Euronext Market Rules following a takeover bid performed under normal rules if (i) Casino held, alone or in concert, at least 90% of the Company's voting rights at the date of the delisting request, (ii) the total amount traded on the Shares in the 12 last months preceding the application for Delisting represented less than 0.5% of the Company's market capitalization, (iii) the application for delisting was filed after 180 days (calendar) had elapsed since the takeover bid made pursuant to the normal procedure preceding this Offer, (iv) Casino pledged, for a period of 3 months from the closing of the takeover bid made in accordance with the normal procedure, to acquire at a price equal to the tender price the Shares held by minority shareholders who would not have tendered to the offer, (V) Casino pledged for a transitional period of an annual financial period following the year in which the delisting of the Company took effect to publish all increasing or decreasing of the threshold of 95% of the share capital or voting rights of the Company and not to propose directly or indirectly to the agenda of a general meeting of shareholders of the Company to modify its corporate form to become a *société par actions simplifiée*.

*Translation for information purposes only.
In case of discrepancy between the French and the English version, the French version shall prevail.*

This Offer and this draft offer document are subject to the review of the AMF

2.3 Agreements which could have a material impact on the valuation or outcome of the Offer

Pursuant to the CBD Support Letter, CBD committed not to tender its Shares into the Offer.

In exchange, in the Casino-CBD Commitment Letter, Casino has made certain commitments to ensure CBD's representation in Cnova's governance and to facilitate Cnova's liquidity, in particular through a market operation, which are described in section 1.3 of this draft offer memorandum.

Furthermore, the Offeror is not party to and is not aware of any other agreement that may affect the valuation or the outcome of the Offer.

3. TERMS AND FEATURES OF THE OFFER

3.1 Features of the Offer

Pursuant to the provisions of Article 231-13 of the AMF General Regulations, J.P. Morgan, in its capacity as presenting bank acting on behalf of the Offeror, filed the Offer on December 6, 2016 in the form of a simplified tender offer (*offre publique d'achat simplifiée*) for the Shares, as set forth in the draft offer document submitted to the AMF. J.P. Morgan guarantees the content and the irrevocable nature of the undertakings given by the Offeror under the Offer in accordance with the provisions of Article 231-13 of the AMF General Regulations.

The Offer and this draft offer document remain subject to review by the AMF.

A notice of filing will be published on the AMF website (www.amf-france.org). In accordance with Article 231-16 of the AMF General Regulations, a press release presenting the key elements of this draft offer document will be released on December 6, 2016. This draft offer document is also available on the AMF website (www.amf-france.org).

The AMF will publish on its website (www.amf-france.org) a clearance decision (*déclaration de conformité*) relating to the Offer after ensuring that the Offer complies with the applicable legal and regulatory provisions. In accordance with such clearance decision, the AMF automatically issues the *visa* on the offer document.

In accordance with Article 231-28 of the AMF General Regulations, the offer document, with the *visa* of the AMF, and the other information relating to the legal, financial and accounting characteristics of the Offeror will be made available upon request to the public for free from the Offeror and J.P. Morgan, no later than the day preceding the opening of the Offer. These documents will also be available on the AMF website (www.amf-france.org), and on the Offeror's.

*Translation for information purposes only.
In case of discrepancy between the French and the English version, the French version shall prevail.*

This Offer and this draft offer document are subject to the review of the AMF

Pursuant to Articles 231-27 and 231-28 of the AMF General Regulations, a press release specifying practical arrangements for obtaining these documents will be published, in accordance with the provisions of Article 221-4 IV of the AMF General Regulations.

Prior to the opening of the Offer, the AMF and Euronext Paris will each publish an opening notice (*avis d'ouverture*) and a notice announcing the timetable and the terms and conditions of the Offer.

The Shares tendered to the Offer must be freely transferable and free of all liens, pledges or all other security or encumbrance restricting the free transfer of their ownership. The Offeror reserves the right to disregard any Shares tendered in the Offer which do not meet this condition.

In accordance with article 233-2, second paragraph, of the AMF General Regulation and in order to align the terms of the Offer with those of the U.S. Offer, the Offer will be centralized by Euronext Paris.

The shareholders of Cnova whose Shares are registered on accounts held by financial intermediaries (credit institutions, investment companies, etc.) and who wish to tender their Shares in the Offer must give to their respective financial intermediary a sale order in the usual form no later than on the expiration of the Offer.

The Company's shareholders whose Shares are held in registered form in the Company's registrar must previously request their conversion to the bearer form and register their shares in financial intermediary books. They shall give to their respective financial intermediary a sale order to tender their shares, as described above.

The sale orders to the Offer may be revoked at any time and up to and including, on the day of the closing of the Offer.

The features mentioned above are subject to the restrictions provided in section 3.8. below.

Each financial intermediary must, on the date indicated in the notice of Euronext Paris, transfer to Euronext Paris the Shares for which they have received a tender order to the Offer. After receipt by Euronext Paris of all orders to tender to the Offer under the conditions described above, Euronext Paris will centralize all these orders and determine the result of the Offer.

No commission will be paid by the Offeror to the financial intermediaries through whom the shareholders tender their Shares in the Offer. The brokerage fees (including commissions and related VAT) related to these acts will be entirely borne by the shareholders tendering their Shares to the Offer.

The AMF will announce the definitive result of the Offer no later than nine (9) trading days after the closing of the Offer and Euronext Paris will indicate in a notice the date and terms of delivery of shares and settlement of capital.

No interest will be payable for the period from the contribution of the shares to the Offer until the settlement-delivery date of the Offer.

*Translation for information purposes only.
In case of discrepancy between the French and the English version, the French version shall prevail.*

This Offer and this draft offer document are subject to the review of the AMF

Shareholders' attention is drawn to the fact that tendering shareholders will remain exposed to EUR/U.S. \$ exchange rate fluctuations until 5:00 p.m. (Paris time) on the business day following the closing of this offer (the time at which the euro / U.S. dollar rate for purposes of converting the offer price from dollars to euros will be fixed). Consequently, the exact amount in euros to be received by tendering shareholders upon the settlement of the Offer, will not be known prior to such time nor, importantly, at the time a tendering shareholder decides to tender his or her shares into the Offer. On the settlement date, Casino will credit Euronext Paris with funds corresponding to the settlement of the Offer. On that date, the shares tendered to the Offer and all rights attached thereto will be transferred to the Casino. Euronext Paris will make the cash settlement to the intermediaries through which the shares have been tendered to the Offer as of the settlement date.

On the settlement date, the Company will credit Euronext Paris with funds corresponding to the settlement of the Offer. On that date, the Shares tendered to the Offer and all rights attached thereto will be transferred to the Offeror. Euronext Paris will make the cash settlement to the intermediaries through which the Shares have been tendered to the Offer as of the settlement date.

3.2 Condition to which the offer is subject

The Offer is not subject to any condition, in particular for obtaining an authorization under merger control or any other regulatory provision.

3.3 Number and nature of the shares targeted by the Offer

In accordance with article 231-6 the AMF General Regulations, although the Offer is technically open to all holders of Shares, including the RS, subject to the reservations included in section 3.8, i.e. 344,507,048 Shares, the Offer will not be accepted by the Offeror and its subsidiaries CBD and Exito with which it is acting in concert, will not tender their Shares to the Offer and Casino will take the necessary measures to promote its contractual and statutory rights so that CBD and Exito will not tender their Shares to the Offer. Therefore, the Offer will only target in practice the Shares other than those held (directly and indirectly) by Casino, CBD and Exito as described below.

As of December 6, 2016, Casino directly owns 190,974,069 Shares representing 55.43 % of the total outstanding Shares. With its subsidiary CBD, which has committed not to tender its shares and its subsidiary Exito which has expressed its intention not to tender its Shares to the Offer and for which Casino, as the parent company having exclusive control over those companies will take the necessary measures to promote its contractual and statutory rights to ensure that they will not tender their Shares to the Offer, Casino owns 308,937,116 Shares representing 89.68 % of the Shares of the Company which are not targeted by the Offer.

Euris holds 2,500,000 Shares of Cnova acquired on its initial public offering and on the market and in any cases more than twelve months prior to the current filing date. Euris has informed the Offeror that it will tender its shares in the Offer prior to the expiration thereof. The Offer tenders these Shares as described below.

*Translation for information purposes only.
In case of discrepancy between the French and the English version, the French version shall prevail.*

This Offer and this draft offer document are subject to the review of the AMF

As indicated in the preamble, the Offer is not targeting the special voting shares which are not transferable except to Cnova under certain circumstances. The Offer does not target the 96,790,798 Distribution Preferred Shares nor the 97,174,855 special voting shares held by Cnova since the Reorganization which are currently being cancelled.

To the Offeror's knowledge, there is no security giving or providing access, immediately or in the future, to the share capital or to the voting rights of the Company, excluding Shares (including RS which are particularly described in section 2.2.4 of this draft offer memorandum), *special voting shares*, DSU and the Distribution Preferred Share which are currently cancelled.

The Offer does not target the DSU as long as they are not transferable, but targets, as the case may be, a maximum number of 172,389 Shares issuable to beneficiaries of DSU governed by the *Sous-Plan Qualifié Français* in the event of death of their beneficiaries. The Offer targets all the RS. Aside of these 172,389 possible additional Shares, no new Shares may be issued under the DSU and the Omnibus Incentive Plan (as defined above) before November 19, 2018.

Thus, as at the date of this draft offer document, **the Offer relates to a maximum number of 35,742,321 Shares**, consisting of (i) the 344,507,048 existing Shares (including the RS), *less* (ii) the 308,937,116 Shares held by the Offeror and its controlled subsidiaries with which it is acting in concert (meaning CBD and Exito), *plus* (iii) the 172,389 Shares arising, as the case may be, from the DSU, governed by the "*Sous-Plan Qualifié Français*".

3.4 Terms of the Offer

The Shareholders of Cnova can tender their Shares to the Offer under the conditions described in this draft offer document.

The Offeror is irrevocably offering to purchase any and all Shares from holders that, pursuant to local laws and regulations applicable to such holders at a price in euros equivalent to U.S. \$5.50 per Share, net to the seller in cash, calculated by using the WM/Reuters index spot exchange rate for euros per U.S. \$ at 5:00 p.m. (Paris time) on the business day following the closing of the offer, rounded down to the nearest thousandth euro; provided, that the global amount paid under each tender order will be rounded down to the nearest lesser euro cent. The Offer is made without prejudice to the restriction provided in section 3.1 above and does not target the Shares held by any subsidiary of the Offeror under its control, namely, CBD and Exito, which will not tender the Shares they hold into the Offer.

*Translation for information purposes only.
In case of discrepancy between the French and the English version, the French version shall prevail.*

This Offer and this draft offer document are subject to the review of the AMF

3.5 Provisional timetable for the Offer

Before the opening of the Offer, the AMF and Euronext Paris will publish notices announcing the opening date and the timetable of the Offer. This timetable below is indicative:

[December 6, 2016	Filing of the draft offer document with the AMF, available to the public and posted on the AMF website (www.amf-france.org) Filing of the draft reply document (<i>projet de note d'information en réponse</i>) with the AMF, including the opinion of the Board of Directors and the report of the independent expert
[December 6], 2016	Circulation of the press release regarding the filing of the draft offer document and the draft reply document [Note WGM: timing of the press release to be discussed]
[December 22], 2016	Issuance by the AMF of a statement of compliance (<i>déclaration de conformité</i>) constituting approval (<i>visa</i>) of the offer document (<i>note d'information</i>) and of the reply document
[December 22], 2016	Publication of the offer and reply documents in accordance with Article 231-27 of the AMF General Regulations
[December 23], 2016	Filing by CASINO with the AMF of the document “other information relating to the characteristics, including legal, financial and accounting ones” of CASINO Filing by Cnova with the AMF of the document “other information relating to the characteristics, including legal, financial and accounting ones” of Cnova
[December 23], 2016	Publication of the documents “other information relating to the characteristics, including legal, financial and accounting one” of Casino and Cnova, in accordance with the article 231-28 the AMF General Regulations
[December 27], 2016	Opening of the Offer
[January 13, 2017]	Cnova’s shareholders’ meeting informing the shareholders about the Offer
[January 25], 2017	Closing of the Offer
[January 26, 2017	Setting up of the euro/dollar exchange rate and announcement of the final price in euros.
[January 31], 2017	Publication by the AMF of a notice announcing the final results of the Offer
[February 2] 2017	Settlement of the Offer by Euronext Paris

*Translation for information purposes only.
In case of discrepancy between the French and the English version, the French version shall prevail.*

This Offer and this draft offer document are subject to the review of the AMF

3.6 Extension of the Offer period

In accordance with Article 231-32 of the AMF General Regulations, opening, closing and results of the Offer will be published by the AMF. During the Offer period, the AMF may postpone the closing date and shall have sole jurisdiction in this regard.

The Offeror reserves the right to ask the AMF, as the case may be, the extension of the closing date in order to make it be aligned with the U.S. Offer closing date if the U.S. Offer is extended.

3.7 Financing of the Offer

3.7.1 Expenses of the Offers

The total cost incurred by the Offeror in connection with the Offers, including, in particular, the fees and other costs of the external financial, legal and accounting advisers and of any experts and any other experts or consultants, as well as communication costs, including the amount of costs relating to the financing of the transaction, is estimated to be approximately EUR 7.6 million (excluding tax).

3.7.2 Cost and financing of the Offers

The cost in connection with the Offer (excluding expenses) in the event all of the Shares not already held by Casino would be tendered, is estimated to a maximum of U.S. \$ 196,582,765.50, i.e. a maximum 184,290,583.58 euros at the indicative 1.0667 EUR/U.S. \$ exchange rate on December 2, 2016.

Payments due by the Offeror in connection with the Offer will be made out of its own resources.

3.8 Restrictions relating to the Offer outside France

The Offer is transmitted to the public exclusively in France.

This draft Offer document is not intended to be distributed in any country other than France.

Generally, the circulation, publication, dissemination, dispatch, or distribution of this document and any other materials relating to this Offer and the making of the Offer may, in some jurisdictions, be restricted by law. This Offer is not being made, directly or indirectly, in, and may not be accepted from within, any jurisdiction in which the making of this Offer or the acceptance thereof would not be in compliance with the laws of that jurisdiction or would require Offeror to make a public offer in any jurisdiction other than France, or the United States in connection with the separate U.S. Offer. Offeror has not sought and will not seek any regulatory approval of any securities exchange authority or similar regulatory authorities (other than competition and anti-trust authorities) outside France and the United States in connection with the French and U.S. Offer, respectively. Persons who come into possession of this document should inform themselves of and comply with any applicable legal restrictions. Any failure to comply with such restrictions may constitute a violation of the securities laws of that jurisdiction. Offeror does not assume any responsibility for any violation by any person of any applicable legal restrictions.

*Translation for information purposes only.
In case of discrepancy between the French and the English version, the French version shall prevail.*

This Offer and this draft offer document are subject to the review of the AMF

The circulation, publication, dissemination, dispatch or distribution of this document and the information contained herein, as well as the Offer itself, is subject to specific restrictions in the United States of America, in accordance with the legislation in force in such jurisdiction:

This draft Offer document does not constitute an extension of the Offer to the United States. The Offer is not being made, directly or indirectly, in or into the United States. Neither this document, nor any other materials relating to the Offer may be circulated, published, disseminated, dispatched or distributed in or into the United States, by the use of the mails or any means or instrumentality of interstate commerce (including post, electronic mail, facsimile transmission, telex and telephone) or any facility of a United States national securities exchange or inter-dealer quotation system, and the Offer may not be accepted by the use of any such means or instrumentality, in or from within the United States.

Accordingly, no copies of this document or any other materials relating to the Offer may be mailed or otherwise circulated, published, disseminated, dispatched or distributed in or into or from within the United States or, in their capacities as such, to custodians, trustees or nominees holding Securities on behalf of persons in the United States, and persons receiving any such documents (including custodians, nominees and trustees) may not circulate, publish, disseminate, dispatch, or distribute them in, into or from within the United States, and doing so will render invalid any relevant purported tendering of Securities in the Offer.

The U.S. Offer is being filed in the United States in parallel to and separately from the Offer and is open to all U.S. Holders, wherever located, pursuant to an offer to purchase and related materials that Offeror intends to file with the US Securities and Exchange Commission (“SEC”) under cover of Schedule TO (the “**U.S. Offer Documents**”).

Any holder of Shares residing in the United States should read and refer to the U.S. Offer Documents described in the previous paragraph, and not the documents relating to the Offer, in making his or her decision whether to tender his or her Shares in the U.S. Offer.

For the purposes of the foregoing paragraphs, “**United States**” shall mean the United States of America, its territories and possessions, any State of the United States, and the District of Columbia.

3.9 Tax regime applicable to the Offer

In the current state of French legislation, the tax regime applicable to the shareholders of Cnova who are resident of France for tax purposes and will participate in the Offer is described hereunder.

The attention of the shareholders is nonetheless drawn to the fact that this information constitutes a mere summary of the tax regime in force and is not meant to constitute a comprehensive analysis of all tax effects likely to apply to them. They are thus invited to contact their usual tax advisor for advice regarding the tax regime applicable to their own situation.

*Translation for information purposes only.
In case of discrepancy between the French and the English version, the French version shall prevail.*

This Offer and this draft offer document are subject to the review of the AMF

This summary is based on the French tax provisions in force as at the date of this Offer document and is therefore likely to be affected by: (i) future changes in French tax rules, which could have a retroactive effect or apply to the current fiscal year; and (ii) by their interpretation from the French tax administration.

Shareholders who are not residents of France should contact their tax advisor.

3.9.1 Individual shareholders who are tax residents of France, who hold the shares in their personal portfolio and who do not carry on a trading activity in conditions which are similar to those of a professional trading activity

(a) General law provision

(i) Personal income tax

Pursuant to Articles 150-0 A *et. seq.* and 200 A of the French Tax Code (“**FTC**”), net capital gains resulting from the disposal of shares are subject to personal income tax at progressive rates (subject to applicable exemptions, as the case may be) after application, concerning the Shares, of a deduction for duration of ownership (as provided by Article 150-0 D of the FTC) equal to:

x) 50% of their amount when the Shares have been held for at least two years and less than eight years, at the date of the transfer;

y) 65% of their amount when the Shares have been held for at least eight years, at the date of the transfer.

It should be noted that following a decision of the French *Conseil d’Etat* dated November 12, 2015 (*CE 12 November 2015 n° 390265, 8e et 3e s.-*), the deduction for duration of ownership does not apply to capital losses on sales.

As a result, the allowance for duration of ownership applies to net gains from sales of shares, i.e., after deduction of capital losses incurred on the sale of shares occurring during the same fiscal year or having occurred during one of the ten previous fiscal years.

For the application of this deduction, the duration of ownership is computed, except in specific cases, from the subscription of the shares or the purchase date.

The persons having deferrable net losses or realised a loss during the sale of the shares of Cnova within the framework of the Offer may offset their losses against capital gains of the same kind realized during the same fiscal year or during the ten following fiscal years as from the year of the realization of such capital loss. In such cases, taxpayers are invited to contact their usual tax advisor in order to assess how such losses may be used.

The contribution of the Shares of Cnova to the Offer is likely to trigger the end of a potential tax deferral or deferment benefiting the holders of these Shares within the framework of prior transactions.

*Translation for information purposes only.
In case of discrepancy between the French and the English version, the French version shall prevail.*

This Offer and this draft offer document are subject to the review of the AMF

(ii) Social security contributions

In addition, capital gains resulting from the transfer of the securities are subject to social security contributions, with no prior application of the deduction for duration of ownership described above, at the global rate of 15.5% allocated as follows:

- 8.2% in respect of general social security contribution (*contribution sociale généralisée*);
- 0.5% in respect of social debt repayment contribution (*contribution au remboursement de la dette sociale*);
- 4.8% in respect of social levy and additional contribution to it; and
- 2% in respect of the solidarity levy.

Except for the general social security contribution, which is deductible up to 5.1 points of the total taxable income during the year of its payment, these social security contributions are not deductible from the taxable income.

(iii) Other contributions

Subject to certain conditions not described in this note, taxpayers who are liable to personal income tax may be subject to the exceptional contribution on high income (*contribution exceptionnelle sur les hauts revenus*) pursuant to the provisions of Article 223 sexies of the FTC.

This contribution is calculated by applying a rate of:

- 3 % to the portion of the income tax reference between 250,000 and 500,000 euros for single, widowed, separated or divorced taxpayers and to the portion of the income tax reference between 500,000 and 1,000,000 euros for taxpayers who file a joint tax return;
- 4 % to the portion of the income tax reference higher than 500,000 euros for single, widowed, separated or divorced taxpayers and to the portion of the income tax reference higher than 1,000,000 euros for taxpayers who file a joint tax return.

The income tax reference of the fiscal household which is mentioned here above is defined pursuant to the provisions of 1° of IV of Article 1417 of the FTC, without any application of the quotient rules defined in Article 163-0 A of the FTC. The income tax reference referred to above notably includes the gross amount of capital gains resulting from the transfer of the securities realized by the concerned taxpayers, prior to the application of the deduction for duration of ownership.

(b) Specific regime applicable to share savings plans (plans d'épargne en actions) ("SSP")

Holders of an SSP are, subject to certain conditions, entitled to an exemption from personal income tax on net income and net capital gains derived from investments in the SSP provided that no withdrawal occurs during the five-year period following the opening of the SSP. Where a shareholder derives a capital loss from the sale of shares held in an SSP, such capital loss may not be offset against capital gains generated by the sale of shares held outside this SSP (save for specific situations not described in this note).

Special provisions, not described in the present note, are applicable in case of closing of or withdrawals from the plan before the end of the fifth year following the opening of the SSP, or if the SSP is settled in the form of a life annuity (*rente viagère*).

*Translation for information purposes only.
In case of discrepancy between the French and the English version, the French version shall prevail.*

This Offer and this draft offer document are subject to the review of the AMF

Persons who hold Shares within a SSP who intend to participate in the Offer are encouraged to contact their usual tax advisor in order to receive advice on the tax regime applicable to their own situation.

3.9.2 Corporate shareholders subject to French corporation tax

Capital gains arising from the sale of the Shares are generally included in the taxable income of the legal entity which is subject to corporate income tax at the ordinary rate of 33.1/3 per cent plus, if applicable, the social contribution amounting to 3.3 per cent of the corporate income tax exceeding 763,000 euros per twelve-month period (Article 235 ter ZC of the FTC).

Companies, achieving a turnover exceeding 250,000,000 euros, are also subject to a temporary corporate tax exceptional surcharge equal to 10.7 % of the corporation tax payable determined before deduction of reductions, tax credits and tax losses of any kind (article 235 ter ZAA of the FTC). However, such contribution is only due in respect of fiscal years closed on or prior to 30 December 2016.

However, companies with a turnover (net of tax) below 7,630,000 euros and with a fully paid-up capital of which 75% has been held in a continuous manner (calculated in accordance with the conditions provide at article 219 I-b of the FTC) during the corresponding tax year by natural or legal persons that comply with these conditions, the capital gains arising from the sale of the shares of the Company are subject to a 15 % tax within a 38,120 euros taxable income limit per twelve-month period. These companies are also exempted from the 3.3 % and 10.7 % social levy contributions mentioned above.

Capital losses incurred on the sale of the Company shares can generally be deducted from the taxable income of the legal entity calculated at the standard corporate income tax rate.

Finally, the contribution of the shares to the Offer may have the effect of ending any postponement or suspension of taxation which would have benefited the holders of these shares as part of previous operations.

Note: the specific tax regime applicable to long-term capital gains provided for by Article 219 I-a quinquies of the FTC, i.e., capital gains derived on the sale of controlling interest (*titres de participation*) is not described in the present note. However, shareholders that fall within the scope of such provisions are invited to consult their usual tax advisor in this respect.

3.9.3 Shareholders subject to a different tax regime

Shareholders who do not fall within the scope of one of the tax treatments mentioned above and who participate in the Offer, including taxpayers whose transactions on securities go beyond simple portfolio management or who have recorded these shares to the active in their trade balance are invited to review their individual tax situation with their usual tax advisors.

*Translation for information purposes only.
In case of discrepancy between the French and the English version, the French version shall prevail.*

This Offer and this draft offer document are subject to the review of the AMF

3.9.4 Registration duties

Pursuant to Article 726 of the FTC, the transfer of securities listed on a regulated market and those traded on a multilateral trading facility within the meaning of Article L. 421-1 of the French Monetary Financial code are not subject to registration duties, unless the transfer (i) is voluntarily registered or (ii) is recorded in a deed signed in France or abroad. In the latter case, the transfer of shares is subject to registration duties at the proportional rate of 0.1 % sitting on the highest of the sale price or the actual value of the shares, subject to certain exceptions described in Article 726, II of the FTC. Pursuant to Article 1712 of the FTC, the registration duties (if any) are due and borne by the transferee (subject to contrary contractual stipulation). However, pursuant to Article 1705 and following of FTC, all parties to the agreement are severally liable for the payment *vis-à-vis* the French tax authorities.

*Translation for information purposes only.
In case of discrepancy between the French and the English version, the French version shall prevail.*

This Offer and this draft offer document are subject to the review of the AMF

4. VALUATION CRITERIA FOR THE OFFER

The valuation works below were prepared before the Reorganization decision was taken (valuation reports can be accessed through the hyperlinks below). Hence, the perimeter of Cnova includes Cnova Brazil.

- Rothschild/Crédit Agricole Corporate and Investment Bank report:
https://www.sec.gov/Archives/edgar/data/1609653/000156761916002782/s001395x1_ex99c3.htm
- Messier Maris & Associés report:
https://www.sec.gov/Archives/edgar/data/1609653/000156761916002782/s001395x1_ex99c4.htm

4.1 Methodology

The price offered by Casino is U.S. \$ 5.50 per Share, converted at the foreign exchange rate EUR/U.S. \$ based on the WM/Reuters index as of 5.00pm (Paris time) the business day following the closing date of the Offer^[15], rounded down to the nearest euro thousandth. The aggregate amount disbursed with respect to each selling order will be rounded down to the nearest euro cent (the “Offer Price”).

The Offer Price in Euro will be released by the Initiator the day of the release of the chosen exchange rate.

Cnova shareholders deciding to tender their Shares in relation to the Offer will be exposed to the foreign exchange rate EUR/U.S. \$ fluctuation until 5.00pm (Paris time), the business day following the Offer closing (as described in section 3.4). At this time and date, the exchange rate will be fixed^[16] and shareholders will know the exact amount in Euro they will receive for each Cnova Share tendered. Hence, when shareholders decide to tender their Shares, they will not know the exact amount in Euro they will receive.

The Offer Price is based on Cnova post Brazilian activities reorganization (as described in section 1.2), namely the transfer of Cnova Brazil operations and Cnova Brazil associated holding costs to Via Varejo in exchange for Via Varejo’s 21.9% stake in Cnova (the resulting treasury shares being cancelled) and a cash balancing payment (net of taxes incurred). Post Brazilian activities reorganization, Cnova encompasses Cdiscount operations and the remaining portion of associated holding costs.

¹⁵ The Exchange rate means the U.S. Dollar/Euro spot rate, expressed as the amount of U.S. Dollars per one Euro for settlement in two WMR Business Days calculated by WM Company which appears on Thomson Reuters Screen WMRSPOT05 Page (or any other page that may replace this page on such service), under the caption “ASK” at or around 5.00 pm Paris Time on the first French Business Day immediately following the last day on which the Targeted Shares can be tendered to the Offer which is also a WMR Business Day; if for any reason the above-mentioned spot rate does not appear on the above mentioned page under the above-mentioned caption on that date and time, the spot rate used will be the next spot rate as defined above appearing on the above mentioned page and under the above-mentioned caption. “WMR Business Day” means any day which is not a Saturday, a Sunday or any other day which is mentioned as a bank holiday by Thomson Reuters on the following service <http://financial.thomsonreuters.com/content/dam/openweb/documents/pdf/financial/wm-reuters-service-alterations.pdf> (or any other page that may replace this page on such service). It is agreed that the (i) WM/Reuters methodology used to calculate spot rates referred to in the definition of the Offer Exchange Rate is described at the following internet address <http://financial.thomsonreuters.com/en/products/data-analytics/market-data/financial-benchmarks/spot-rates.htm> 1, (ii) J.P. Morgan and its affiliates participate in the WM/Reuters spot rate benchmark process and as a principal market maker in the foreign exchange market and (iii) J.P. Morgan’s activities may adversely influence the Offer Exchange Rate, including as further described in the Disclosure to Wholesale Fixed Income, Currency, Commodities and Equities Products Clients available at: <https://www.jpmorgan.com/country/US/en/disclosures/ficcequities>.

¹⁶ Same as footnote above.

*Translation for information purposes only.
In case of discrepancy between the French and the English version, the French version shall prevail.*

This Offer and this draft offer document are subject to the review of the AMF

A multi-criteria analysis, based on standard valuation methods taking into account Cnova's industry characteristics as well as the features of the Offer, has been conducted by J.P. Morgan, on behalf of the Offeror.

The valuation analyses were performed using information provided by the Offeror, public information available on the Company, information on the industry and the Company's competitors, as well as discussions with the management of the Company. It was not within J.P. Morgan's scope of work to, and J.P. Morgan did not, verify this information or submit it to an independent audit, or verify or assess the assets and / or liabilities of the Company.

4.2 Sources of information and assumptions

4.2.1 Sources of information

The analyses shown hereafter are based on the following information sources:

- Cnova consolidated and audited 2013, 2014 and 2015 annual accounts released on July 22, 2016;
- Cnova consolidated and unaudited quarterly accounts as of September 30, 2016 released on October 26, 2016;
- The 2016E-2018E business plan of Cdiscount provided by Cnova management, approved by Cnova Board of Directors as part of Cnova global standalone business plan review on February 23, 2016 and confirmed by management post Q3 2016 results. The latest 2016 estimates were provided by Cnova management on November 18, 2016. Several due diligence sessions have been conducted between J.P. Morgan and Cnova management to understand the underlying assumptions of the business plan and to derive mid and long term extrapolations of the latter;
- Public information on the Company and other peer companies mentioned in this document;
- The following databases: AMF website, SEC website, Economic Intelligence Unit (EIU), Factset, Dealogic, Mergermarket, Bloomberg, Thomson.

From a general perspective, all figures and assumptions (in particular for the purposes of extrapolations of the Business Plan) have been discussed with Cnova management.

*Translation for information purposes only.
In case of discrepancy between the French and the English version, the French version shall prevail.*

This Offer and this draft offer document are subject to the review of the AMF

4.2.2 Equity value (“EqV”) to Firm value (“FV”) adjustments

The items listed below have been retained in the subsequent valuation analyses (where applicable). Equity value is derived by adding “Total equity value to firm value adjustments” (as listed below) to Firm value. These elements are used for the Discounted Cash Flows approach (as described in section 4.4.1.) and in the trading multiples method (as described in section 4.4.2.).

As of September 30, 2016	€mm
Adjusted Net Cash / (Adjusted Net debt)	14
<i>o/w Net financial debt - Cnova reported balance sheet</i>	<i>50</i>
<i>o/w Working capital adjustments - See below</i>	<i>(36)</i>
<i>Non-controlling interests - See below</i>	<i>(6)</i>
<i>Current and non-current provisions - Cnova reported balance sheet</i>	<i>(18)</i>
<i>NOL valuation - See below</i>	<i>59</i>
Total equity value to firm value adjustments	49

“Working capital adjustments” item is defined as the difference between normalized working capital and working capital computed as of September 30, 2016. Normalized working capital is itself defined as the average working capital over the last twelve months to September 30, 2016.

“Non-controlling interests” item is defined as the fair value of the 0.35% consolidated non-controlling interests in “Cdiscount” entity (indirectly held by Cnova through “Cdiscount Group”). The fair value itself is derived from mid-point Discounted Cash Flows (“DCF”) valuation of “Cdiscount” entity.

“Current and non-current provisions” item comprises U.S. \$ 1 million provision related to the ongoing Cnova Shareholder Lawsuit^[17], corresponding to the associated insurance policies deductible. It does not include any provision related to the penalty imposed by the SEC, in connection with the investigation into Cnova accounting practices. Any difference between the amount of this “Current and non-current provisions” item and the final amount to be paid by Cnova could significantly impact the conclusion of J.P. Morgan’s analyses.

“NOL valuation” item is defined as the present value of Net Operating Losses (“NOL”) available from a tax perspective at Cnova level (assuming a normative tax rate of 34.43%). The present value of 59 million euros presented in the table above as a cash-like item is based on an actionable amount of NOL of 205 million euros as of September 30, 2016, increased by the expected accumulated losses in 2016E-2017E and discounted at a cost of equity of 7.7% (equal to WACC given target gearing of 0%, as described in section 4.4.1.).

4.2.3 Number of Shares

The following valuation analyses assume a diluted Share capital of 345,797,205 Shares, including (i) 344,507,048 common Shares as of September 30, 2016 (including RS), pro forma for the capital reduction of 96,790,798 treasury shares received from Via Varejo as part of Brazilian activities reorganization and (ii) dilution adjustment of 1,290,157 Shares coming from DSU attributable to Cnova’s employees.

¹⁷ One of J.P. Morgan’s affiliates is a defendant in the US shareholders lawsuit as it was the Joint Global Coordinator of Cnova’s IPO.

*Translation for information purposes only.
In case of discrepancy between the French and the English version, the French version shall prevail.*

This Offer and this draft offer document are subject to the review of the AMF

4.2.4 Foreign exchange assumptions

Conversion between EUR and U.S. \$ is assuming EUR 1.00 = U.S. \$ 1.10, 1-month average exchange rate as of October 28, 2016 for the valuation work.

Implied premium and discounts calculated for each valuation method are based on spot foreign exchange rate EUR/U.S. \$ as of November 10, 2016 of 1.09 (the “**Foreign Exchange Rate**”). The latter are purely illustrative and shown for information purposes only. Actual implied premium / discounts compared to Offer Price in Euro are based on the WM/Reuters index as of 5.00pm (Paris time) the business day following the closing date of the Offer^[18], rounded down to the nearest euro thousandth. The aggregate amount disbursed with respect to each selling order will be rounded down to the nearest euro cent.

The Offer Price in Euro will be released by the Initiator the day of the release of the chosen exchange rate.

Cnova shareholders deciding to tender their Shares in relation to the Offer will be exposed to the foreign exchange rate EUR/U.S. \$ fluctuation until 5.00pm (Paris time), the business day following the Offer closing (as described in section 3.4). At this time and date, the exchange rate will be fixed^[19] and shareholders will know the exact amount in Euro they will receive for each Cnova Share tendered. Hence, when shareholders decide to tender their Shares, they will not know the exact amount in Euro they will receive.

4.3 Valuation assessment methodologies

4.3.1 Primary valuation methods

The Discounted Cash Flows (“DCF”) is the primary methodology used to determine the valuation range.

¹⁸ The Exchange rate means the U.S. Dollar/Euro spot rate, expressed as the amount of U.S. Dollars per one Euro for settlement in two WMR Business Days calculated by WM Company which appears on Thomson Reuters Screen WMRSPOT05 Page (or any other page that may replace this page on such service), under the caption “ASK” at or around 5.00 pm Paris Time on the first French Business Day immediately following the last day on which the Targeted Shares can be tendered to the Offer which is also a WMR Business Day; if for any reason the above-mentioned spot rate does not appear on the above mentioned page under the above-mentioned caption on that date and time, the spot rate used will be the next spot rate as defined above appearing on the above mentioned page and under the above-mentioned caption. “WMR Business Day” means any day which is not a Saturday, a Sunday or any other day which is mentioned as a bank holiday by Thomson Reuters on the following service <http://financial.thomsonreuters.com/content/dam/openweb/documents/pdf/financial/wm-reuters-service-alterations.pdf> (or any other page that may replace this page on such service). It is agreed that the (i) WM/Reuters methodology used to calculate spot rates referred to in the definition of the Offer Exchange Rate is described at the following internet address <http://financial.thomsonreuters.com/en/products/data-analytics/market-data/financial-benchmarks/spot-rates.htm> 1, (ii) J.P. Morgan and its affiliates participate in the WM/Reuters spot rate benchmark process and as a principal market maker in the foreign exchange market and (iii) J.P. Morgan’s activities may adversely influence the Offer Exchange Rate, including as further described in the Disclosure to Wholesale Fixed Income, Currency, Commodities and Equities Products Clients available at: <https://www.jpmorgan.com/country/US/en/disclosures/ficcequities>.

¹⁹ Same as footnote above.

*Translation for information purposes only.
In case of discrepancy between the French and the English version, the French version shall prevail.*

This Offer and this draft offer document are subject to the review of the AMF

4.3.2 Valuation methods used for indicative purposes

The following methodologies were used as illustrative references to assess the Offer Price:

- Peer trading multiples;
- Share price analysis (including brokers' target prices).

4.3.3 Disregarded valuation methods

The following methods were disregarded to analyse the Offer Price, as they were not considered relevant:

- Peer group transaction multiples

The peer group transaction multiples method is an analogical valuation approach based on precedent transactions with similar characteristics to the considered transaction. This methodology reflects the premium an investor is willing to pay for acquiring a strategic stake in a company. Transaction multiples may also integrate the investor's perception of potential synergies to be expected from a combination of acquirer's and target's businesses. Therefore, this valuation methodology is not suitable in the context of the Offer as the Offeror already holds directly and indirectly approximately 90% or more of the Share capital and voting rights of Cnova (post transfer of Cnova Brazil to Via Varejo and the related reduction in the Share capital by Cnova as described in section 4.2.3.) and as a result, there will be no change of control or control premium paid because the Offer only targets the acquisition of a minority stake.

- Discounted Dividends Model

The discounted dividends model consists in carrying out a direct valuation of the company's equity based on future dividends projections discounted at the cost of equity. This methodology is relevant only for companies with a history of distributing significant dividends in a regular and predictable manner. As Cnova has not paid any dividend since its IPO, this methodology is thus irrelevant for assessing Cnova equity value.

- Net Asset Value ("Actif Net Comptable")

This approach, which relies on the historical carrying value of the assets and the liabilities of the Company, has not been retained as it does not properly reflect the real value and future perspectives of the business.

- Revalued Net Asset Value ("Actif Net Réévalué")

This methodology consists in adjusting the Net Asset Value discussed previously by potential capital gains or losses related to some of the Company's assets and liabilities. This approach is generally retained for the valuation of financial portfolio companies with several minority investments. This approach has been discarded for Cnova as it fully controls the operational assets of its sole subsidiary Cdiscount.

This Offer and this draft offer document are subject to the review of the AMF

4.4 Methods used to assess the valuation

4.4.1 Discounted Cash Flows (DCF)

This methodology consists in determining the intrinsic value of the Company by discounting the future free cash flows generated by its assets. The firm value is equal to the sum of discounted cash flows over a foreseeable horizon (between September 30, 2016 and 2024E) and a terminal value, representing the sum of infinite series of cash flows beyond this horizon. The value attributable to the shareholders is obtained by adding “Total equity value to firm value adjustments” (as described in section 4.2.2) to firm value and then dividing this equity value by total diluted number of Shares (as described in section 4.2.3.).

The DCF valuation was conducted as of September 30, 2016.

The free cash-flows retained for DCF are derived from 2016 budget and 2017E-2018E business plan prepared by the Company as well as the extrapolations prepared by J.P. Morgan and discussed with Cnova management.

Financial aggregates and free cash flows retained for DCF are based on the business plan prepared by the Company over the period 2016E-2018E:

- Sales CAGR of 7.7% between 2016E and 2018E;
- EBITDA margin (pre-holding costs) increasing from 0.9% in 2016E to 4.7% in 2018E;
- Holding costs decreasing from 1.2% of Sales in 2016E to 0.4% in 2018E;
- Factoring costs decreasing from 1.9% of Sales in 2016E to 1.3% in 2018E;
- D&A increasing from 51.3% of Capex in 2016E to 60.8% in 2018E;
- Change in WC increasing from 0.3% of Sales in 2016E to 1.0% in 2018E;
- Capex increasing from 2.2% of Sales in 2016E to 2.3% in 2018E;

J.P. Morgan has prepared extrapolations after discussion with Cnova management over the period 2019E-2024E:

- Sales CAGR of 9.9% between 2019E and 2024E with a terminal growth rate of 2.25%, +0.25% above French long term inflation rate of 2.00% given by EIU, to reflect higher penetration rate of e-Commerce;
- Gradual improvement driven by Marketplace development towards a normative 8.0% EBITDA margin (pre-holding costs) of revenues;
- Holding costs growing at 2.0% annual inflation rate;
- Stable factoring costs level of 1.3% of Sales from 2019E until normative year;
- Increasing D&A towards normative level of 95.0% of Capex;
- Change in WC gradually decreasing to normative level of 0.2% of Sales;
- Capex gradually decreasing to normative level of (2.0%) of Sales.

*Translation for information purposes only.
In case of discrepancy between the French and the English version, the French version shall prevail.*

This Offer and this draft offer document are subject to the review of the AMF

A mid-point weighted average cost of capital (“WACC”) of Cnova of 7.7% has been used, which relies on the following assumptions:

- A risk free rate of 0.4% (source: J.P. Morgan research (EUR), as of October 2016);
- A market risk premium of 7.6% (source: J.P. Morgan research (EUR), as of October 2016);
- An unlevered beta (asset beta) of 0.95, calculated as the average of unlevered asset betas of Amazon, AO World, JD.com and Qliro, themselves deriving from respective local historical 2-year weekly Bloomberg adjusted betas as of October 28, 2016;
- A target debt to equity ratio of 0% (in line with sector average).

The terminal value, representing 79.5% of the firm value, was determined using the Gordon-Shapiro formula based on the following normative assumptions:

- A long-term growth rate of Sales of 2.25% of Sales;
- A normative EBITDA margin of 8.0% of Sales;
- Normative capital expenditures representing 2.0% of Sales;
- A level of depreciation & amortization equal to 95.0% of capital expenditures in the normative year;
- A normative change in working capital estimated to remain stable at 0.2% of Sales.

A sensitivity analysis of the firm value and equity value per Share obtained by this methodology was conducted based on the weighted average cost of capital and on the long-term growth rate:

- Weighted average cost of capital ranging from 6.7% to 8.7%, with a selected range from 7.2% to 8.2%;
- Long-term growth rate ranging from 1.75% to 2.75%, with a selected range from 2.00% to 2.50%.

		Firm value (€mm)				
		WACC				
		6.7%	7.2%	7.7%	8.2%	8.7%
Long-term growth rate	1.75%	1,746	1,561	1,407	1,278	1,167
	2.00%	1,853	1,647	1,479	1,338	1,219
	2.25%	1,971	1,743	1,558	1,404	1,275
	2.50%	2,104	1,849	1,644	1,476	1,335
	2.75%	2,254	1,967	1,739	1,554	1,400

*Translation for information purposes only.
In case of discrepancy between the French and the English version, the French version shall prevail.*

This Offer and this draft offer document are subject to the review of the AMF

		Equity value per share (€)				
		WACC				
		6.7%	7.2%	7.7%	8.2%	8.7%
Long-term growth rate	1.75%	5.2	4.7	4.2	3.8	3.5
	2.00%	5.5	4.9	4.4	4.0	3.7
	2.25%	5.8	5.2	4.6	4.2	3.8
	2.50%	6.2	5.5	4.9	4.4	4.0
	2.75%	6.7	5.8	5.2	4.6	4.2

Based on the sensitivity analysis above, the equity value per Share of Cnova ranges from 4.0 euros to 5.5 euros, corresponding to a firm value ranging from 1,338 to 1,849 million euros. The central equity value per Share is equal to 4.6 euros, corresponding to a firm value of 1,558 million euros.

Therefore, based on the Discounted Cash Flows approach, for illustrative purposes only as indicated in section 4.2.4, the Offer Price of 5.1 euros converted using the Foreign Exchange Rate would represent a premium / (discount) of 26.0% / (7.9)% over the range of equity value per Share selected.

The Discounted Cash Flows valuation conducted above is based on a central case for holding costs (post Cnova Brazil carve-out), assuming conservation of NASDAQ and Euronext reporting and no squeeze-out. Should NASDAQ and Euronext reporting be removed and a squeeze-out be implemented, it would translate into an upside of 0.16 euros per Share (assuming allocation to 100% of Share capital).

4.4.2 Trading multiples

This methodology consists in determining the value of Cnova by applying the multiples observed from a sample of selected comparable publicly-traded companies to its financials (based on the business plan prepared by Cnova management).

The following sample of comparable online-retail listed companies was used in the analysis:

- **JD.com**, a Chinese online-retail company engaged in the sale of electronics and home appliance products, as well as general merchandise products (including audio, video products and books) sourced from manufacturers, distributors and publishers in China through its website. It also offers an online marketplace that enables third-party vendors to sell their products to customers on the Company's website. JD.Com is a comparable to Cnova primarily because it is a single-country e-Commerce player (China) and country leader in traffic, and also thanks to its similar primary focus on consumer electronics and appliances carrying low margins and high volume plays. However, China has a significantly different macroeconomic outlook compared to France which is a differentiating factor compared to Cnova.
- **AO World**, a British online-retail company specialised in online retailing of domestic appliances to customers in the United Kingdom. The Company also provides delivery and installation services. AO World is a single-country e-Commerce player and primarily focuses on home appliances, which makes it a good comparable to Cnova. However, the lack of marketplace activity in AO World's business model (which tends to improve margins) is a differentiating factor compared to Cnova.

*Translation for information purposes only.
In case of discrepancy between the French and the English version, the French version shall prevail.*

This Offer and this draft offer document are subject to the review of the AMF

- **Qliro**, a Swedish online-retail company offering a range of products and services through its websites to customers in Nordic countries including merchandise and content purchased for resale from vendors and products offered by third-party sellers. As such, Qliro business model is close to Cnova's, being both a merchant and a marketplace ("hybrid" e-Commerce model). However, Qliro is much smaller than Cnova in terms of market capitalization and turnover, which is a differentiating factor.
- **Amazon**, a US online-retail company offering a range of products and services through its websites, including merchandise and content it purchases for resale from vendors and those offered by third-party sellers. As such, Amazon's business model is close to Cnova's, being both a merchant and a marketplace ("hybrid" e-Commerce model). However, some of Amazon's features constitute limits of comparability: Amazon has a more diverse business model which now includes new services (e.g. Amazon Web Services) which have lifted considerably the operating margin (Amazon is no longer a pure e-Commerce comparable). Finally, Amazon operates globally. As a consequence, it is excluded from average and median calculations.

Given the lack of perfect comparability between Cnova and the publicly-traded companies selected, the trading multiples methodology has been retained for indicative purposes only.

FV/Sales multiples are deemed to be more relevant than FV/EBITDA and FV/EBIT multiples as the latter are not always meaningful due to differences in companies' reporting standards and operating profiles (some of the selected companies being unprofitable at EBITDA and EBIT levels in the coming years).

In order to apply the trading multiples methodology, firm values of the selected companies listed above have been computed as follows:

Market capitalisation (as of October 28, 2016)

+ Latest available net debt

+ Book value of minority interests

+ Pension provisions after tax

– Book value of financial assets accounted for using the equity method

Sales, EBITDA and EBIT forecasts are based on the IBES consensus (Factset consensus of equity research analysts who follow these companies on a regular basis) as of October 28, 2016.

*Translation for information purposes only.
In case of discrepancy between the French and the English version, the French version shall prevail.*

This Offer and this draft offer document are subject to the review of the AMF

The table below presents a selection of key operating metrics for the group of companies selected (Average and Median exclude Amazon):

Company	Sales (€mm)		Sales CAGR 2015-2017	EBITDA (€mm)		EBITDA margin	
	2016	2017		2016	2017	2016	2017
JD.com	34,017	44,557	30.0%	250	432	0.7%	1.0%
AO World	767	930	21.2%	0	12	0.0%	1.3%
Qliro Group	462	466	(5.6%)	(2)	14	(0.4%)	3.0%
Average			15.2%			0.1%	1.7%
Median			21.2%			0.0%	1.3%
<i>Amazon - For illustration</i>	125,312	153,832	25.3%	13,858	18,379	11.1%	11.9%

Source: Company information, Factset as of October 28, 2016

The table below presents a selection of key valuation ratios for the group of companies selected (Average and Median exclude Amazon):

Company	Market cap. (€mm)	FV (€mm)	FV/Sales		FV/EBITDA		FV/EBIT	
			2016	2017	2016	2017	2016	2017
JD.com	34,204	29,759	0.87x	0.67x	119.1x	68.8x	NM	NM
AO World	763	741	0.97x	0.80x	NM	62.1x	NM	140.7x
Qliro Group	146	167	0.36x	0.36x	NM	12.1x	NM	21.4x
Average			0.73x	0.61x	NM	47.7x	NM	NM
Median			0.87x	0.67x	NM	62.1x	NM	NM
<i>Amazon - For illustration</i>	337,526	336,734	2.69x	2.19x	24.3x	18.3x	88.1x	50.6x

Source: Company information, Factset as of October 28, 2016

The table below presents the implied valuation for Cnova when considering FV/Sales multiples^[20]:

(€mm)	2016		2017	
	Low	High	Low	High
Cnova revenues	1,839	1,839	1,968	1,968
Primary multiples	0.73x	0.97x	0.61x	0.80x
Implied Cnova firm value	1,350	1,776	1,195	1,567
Implied Cnova equity value	1,399	1,825	1,244	1,616
Implied equity value per share (€)	4.0	5.3	3.6	4.7
Premium / (Discount) implied by the Offer price	24.9%	(4.2%)	40.5%	8.2%

For both years, high-end of the range is based on AO World multiple, considered as the most comparable peer to Cnova, and low-end of the range is based on the average of peer set multiples excluding Amazon.

²⁰ Premium / (Discounts) are given for illustrative purposes only as indicated in section 4.2.4. using the Offer Price of 5.1 euros converted with the Foreign Exchange Rate.

*Translation for information purposes only.
In case of discrepancy between the French and the English version, the French version shall prevail.*

This Offer and this draft offer document are subject to the review of the AMF

Applying the respective ranges of 2016 and 2017 FV/Sales peer set multiples to Cnova's revenue figures results in an implied firm value ranging between 1,350 million euros and 1,776 million euros based on 2016 revenues and an implied firm value ranging between 1,195 million euros and 1,567 million euros based on 2017 revenues. This results in an implied equity value per Share ranging between 4.0 euros and 5.3 euros based on Cnova's 2016 revenues and ranging between 3.6 euros and 4.7 euros based on 2017 revenues.

Therefore, based on the trading multiples approach, for illustrative purposes only as indicated in section 4.2.4, the Offer Price of 5.1 euros converted using the Foreign Exchange Rate would represent a premium / (discount) of 24.9% / (4.2)% over the range of equity value per Share based on the 2016 multiples and of 40.5% / 8.2% over the range of equity value per Share based on the 2017 multiples.

4.4.3 Share price evolution

Cnova's Shares are admitted for trading in Euro on Euronext Paris (Compartment A) under the ISIN code NL0010949392 (mnemonic code: "CNV").

Cnova's Shares are admitted for trading in U.S. \$ on the NASDAQ Global Select Market under the ISIN code NL0010949392 (mnemonic code: "CNV").

Over the last twelve month prior to the announcement, on May 12, 2016, of the execution of a non-binding memorandum of understanding with respect to the Transactions (including the Offer):

- Daily trading volumes on NASDAQ reached approximately 87,840 Shares on average, which corresponds to 5.2% of Share capital^[21].
- Daily trading volumes on Euronext Paris reached approximately 6,274 Shares on average, which corresponds to 0.4% of Share capital^[22].

Due to limited size of the free float and limited turnover as illustrated above, the Share price evolution methodology has been retained for reference purposes only.

The tables below present the premium implied by the Offer, over a selection of Cnova's trading indicators calculated as of October 28, 2016^[23] on NASDAQ and Euronext Paris.

Listing on Nasdaq^[24]

	Equity value per Share (€)	Premium (discount) implied by the Offer Price
Last price at October 28, 2016	4.9	3.1%
1-month VWAP at October 28, 2016	4.9	4.0%
3-month VWAP at October 28, 2016	4.7	7.0%
6-month VWAP at October 28, 2016	4.5	12.3%
12-month VWAP at October 28, 2016	3.5	46.5%
12-month high at October 28, 2016	4.9	2.2%
12-month low at October 28, 2016	2.0	155.4%
12-month VWAP prior to the announcement, on May 12, 2016, of the execution of a non-binding memorandum of understanding with respect to the Transactions (including the Offer)	3.3	53.2%
Last price at May 11, 2016 (prior to the announcement, on May 12, 2016, of the execution of a non-binding memorandum of understanding with respect to the Transactions (including the Offer))	3.0	70.0%
Last price at April 27, 2016 (prior to first leak, on April 28, 2016, about Cnova potential restructuring in Brazilian press)	2.7	88.7%
Average brokers target price	5.0	1.5%

²¹ Calculated as the cumulated volume traded over the period divided by the total number of Cnova Shares (441,297,846), before the capital reduction of 96,790,798 treasury shares received from Via Varejo as part of Brazilian activities reorganization (as described in section 4.2.3).

²² Calculated as the cumulated volume traded over the period divided by the total number of ordinary Cnova shares (441,297,846), before capital reduction of 96,790,798 treasury shares received from Via Varejo as part of Brazilian activities reorganization (as described in section 4.2.3).

²³ A daily exchange rate was used for market data.

²⁴ Premium / (Discounts) are given for illustration purposes only as indicated in section 4.2.4. using the Offer Price of 5.1 euros converted with the Foreign Exchange Rate.

*Translation for information purposes only.
In case of discrepancy between the French and the English version, the French version shall prevail.*

This Offer and this draft offer document are subject to the review of the AMF

Therefore, for illustrative purposes only as indicated in section 4.2.4, the Offer Price of 5.1 euros converted using the Foreign Exchange Rate implies a premium of 4.0%, 7.0%, 12.3% and 46.5% to the volume-weighted average price over, respectively, one, three, six and twelve months to October 28, 2016 and a premium of 53.2% to the volume-weighted average price over 12 months to May 12, 2016. It implies a premium of 155.4% and 2.2% respectively to the minimum and maximum closing prices over the twelve months to October 28, 2016. It implies a premium of 70.0% to the closing price at May 11, 2016 prior to the announcement of the execution of a non-binding memorandum of understanding with respect to the Transactions and 88.7% to the closing price of April 27, 2016, prior to first leaks about Cnova potential restructuring in Brazilian press. It implies a premium of 1.5% to the average broker target price of October 28, 2016.

Listing on Euronext^{[25],[26]}

	Equity value per Share (€)	Premium/ (discount) implied by the Offer Price
Last price at October 28, 2016	4.9	3.4%
1-month VWAP at October 28, 2016	4.8	4.5%
3-month VWAP at October 28, 2016	4.7	7.3%
6-month VWAP at October 28, 2016	4.5	12.5%
12-month VWAP at October 28, 2016	3.5	46.4%
12-month high at October 28, 2016	4.9	2.5%
12-month low at October 28, 2016	2.0	152.8%
VWAP over 60 trading days prior to the announcement, on May 12, 2016, of the execution of a non-binding memorandum of understanding with respect to the Transactions (including the Offer)	2.5	100.5%
12-month VWAP prior to the announcement, on May 12, 2016, of the execution of a non-binding memorandum of understanding with respect to the Transactions (including the Offer)	3.3	52.1%
Last price at May 11, 2016 (prior to the announcement, on May 12, 2016, of the execution of a non-binding memorandum of understanding with respect to the Transactions (including the Offer))	2.9	73.1%
Last price at April 27, 2016 (prior to first leak, on April 28, 2016, about Cnova potential restructuring in Brazilian press)	2.8	80.6%

Source: Factset as of October 28, 2016

Therefore, for illustrative purposes only as indicated in section 4.2.4, the Offer Price of 5.1 euros converted using the Foreign Exchange Rate implies a premium of 4.5%, 7.3%, 12.5%, and 46.4% to the volume-weighted average price over, respectively, one, three, six and twelve months to October 28, 2016 and a premium of 52.1% to the volume-weighted average price over 12 months to May 12, 2016. It implies a premium of 152.8% and 2.5% respectively to the minimum and maximum closing prices over the twelve months to October 28, 2016. It implies a premium of 73.1% to the closing price at May 11, 2016 prior to the announcement of the execution of a non-binding memorandum of understanding with respect to the Transactions and 80.6% to the closing price of April 27, 2016, prior to first leaks about Cnova potential restructuring in Brazilian press. Lastly, it implies a premium of 100.5% to the volume-weighted average price over 60 trading days prior to the memorandum of understanding signing announcement date (12 May 2016) ^[27].

²⁵ Premium / (Discounts) are given for illustration purposes only as indicated in section 4.2.4. using the Offer Price of 5.1 euros converted with the Foreign Exchange Rate.

²⁶According to AMF rules (Art. 233-3) offer price must be higher than Euronext VWAP over 60 trading days prior to announcement of the offer (12 May 2016).

²⁷According to AMF rules (Art. 233-3) offer price must be higher than Euronext VWAP over 60 trading days prior to announcement of the offer (12 May 2016).

*Translation for information purposes only.
In case of discrepancy between the French and the English version, the French version shall prevail.*

This Offer and this draft offer document are subject to the review of the AMF

4.5 Valuation summary

Therefore, for illustrative purposes only as indicated in section 4.2.4, the Offer Price of 5.1 euros converted using the Foreign Exchange Rate is compared to the methods and reference information shown in the table below:

Methodology	Equity value per Share (€)	Implied premium/(discount)
Discounted Cash Flows - Low range	4.0	26.0%
Discounted Cash Flows - High range	5.5	(7.9%)
Trading comparables 2016 - Low	4.0	24.9%
Trading comparables 2016 - High	5.3	(4.2%)
Trading comparables 2017 - Low	3.6	40.5%
Trading comparables 2017 - High	4.7	8.2%
NASDAQ		
Last price at October 28, 2016	4.9	3.1%
1-month VWAP at October 28, 2016	4.9	4.0%
3-month VWAP at October 28, 2016	4.7	7.0%
6-month VWAP at October 28, 2016	4.5	12.3%
12-month VWAP at October 28, 2016	3.5	46.5%
12-month high at October 28, 2016	4.9	2.2%
12-month low at October 28, 2016	2.0	155.4%
12-month VWAP prior to the announcement, on May 12, 2016, of the execution of a non-binding memorandum of understanding with respect to the Transactions (including the Offer)	3.3	53.2%
Last price at May 11, 2016 (prior to the announcement, on May 12, 2016, of the execution of a non-binding memorandum of understanding with respect to the Transactions (including the Offer))	3.0	70.0%
Last price at April 27, 2016 (prior to first leak, on April 28, 2016, about Cnova potential restructuring in Brazilian press)	2.7	88.7%
Average brokers target price	5.0	1.5%
Euronext		
Last price at October 28, 2016	4.9	3.4%
1-month VWAP at October 28, 2016	4.8	4.5%
3-month VWAP at October 28, 2016	4.7	7.3%
6-month VWAP at October 28, 2016	4.5	12.5%
12-month VWAP at October 28, 2016	3.5	46.4%
12-month high at October 28, 2016	4.9	2.5%
12-month low at October 28, 2016	2.0	152.8%
VWAP over 60 trading days prior to the announcement, on May 12, 2016, of the execution of a non-binding memorandum of understanding with respect to the Transactions (including the Offer)	2.5	100.5%
12-month VWAP prior to the announcement, on May 12, 2016, of the execution of a non-binding memorandum of understanding with respect to the Transactions (including the Offer)	3.3	52.1%
Last price at May 11, 2016 (prior to the announcement, on May 12, 2016, of the execution of a non-binding memorandum of understanding with respect to the Transactions (including the Offer))	2.9	73.1%
Last price at April 27, 2016 (prior to first leak, on April 28, 2016, about Cnova potential restructuring in Brazilian press)	2.8	80.6%

*Translation for information purposes only.
In case of discrepancy between the French and the English version, the French version shall prevail.*

This Offer and this draft offer document are subject to the review of the AMF

5. PERSONS RESPONSIBLE FOR THE OFFER DOCUMENT

5.1 For the Offeror

“To our knowledge, the information contained in this offer document is in accordance with the facts and nothing has been omitted which could affect the import thereof”.

5.2 For the presentation of the Offer

“In accordance with Article 231-18 of the AMF General Regulations, J.P. Morgan, the financial institution presenting the Offer, declares that to its knowledge, the presentation of the Offer, examined on the basis of information provided by the Offeror, and the criteria for determining the proposed price are in accordance with the facts and nothing has been omitted which could affect the import thereof.”.

J.P. Morgan

*Translation for information purposes only.
In case of discrepancy between the French and the English version, the French version shall prevail.*

DRAFT INFORMATION MEMORANDUM

ESTABLISHED BY THE COMPANY



CNOVA N.V.

**IN RESPONSE TO THE DRAFT PUBLIC TENDER OFFER INITIATED BY
CASINO, GUICHARD-PERRACHON S.A.**



This draft memorandum in response has been filed with the *Autorité des marchés financiers* (the French Financial Markets Authority (“**AMF**”)) on December 6, 2016, in accordance with Article 231-19 and 231-26 of the AMF General Regulations.

Pursuant to Articles 231-19, 261-1 *et seq.* of the AMF General Regulation, the report of Eight Advisory, acting as independent expert, is included in this draft information memorandum in response.

This draft memorandum in response remains subject to the review of the AMF.

This draft information memorandum in response is available on the websites of Cnova N.V. (<http://www.cnova.com/en/>) and the AMF (www.amf-france.org) and may be obtained free of charge at:

**Cnova N.V.
Schiphol Boulevard 273
1118 BH Schiphol, The Netherlands**

Pursuant to article 231-28 of the AMF General Regulations, information relating in particular to the legal, financial and accounting characteristics of Cnova N.V. will be filed with the AMF and made available to the public no later than on the day preceding the opening of the tender offer.

*Translation for information purposes only.
In case of discrepancy between the French and the English version, the French version shall prevail.*

The Offer and this draft information memorandum in response remain subject to the review of the AMF

TABLE OF CONTENTS

I. PRESENTATION OF THE OFFER	3
1.1. CONTEXT OF AND RATIONALE FOR THE TRANSACTION	6
1.1.1. Presentation of the Company and background of the transaction	6
1.1.2. Context of the Offer	19
1.1.3. Transaction agreements	24
II. ELEMENTS THAT COULD HAVE AN IMPACT IN CASE OF A PUBLIC OFFER	34
2.1. DETAILS OF THE COMPANY'S CAPITAL	34
2.1.1. Double Voting Rights Structure	34
2.1.2. Capital distribution	35
2.2. SHARES GIVING ACCESS TO THE COMPANY'S CAPITAL	36
2.3. STATUTORY RESTRICTIONS ON THE EXERCISE OF VOTING RIGHTS AND SHARE TRANSFERS - AGREEMENTS KNOWN BY THE COMPANY PURSUANT TO ARTICLE L. 233-11 OF THE FRENCH COMMERCIAL CODE	36
2.4. DIRECT AND INDIRECT HOLDINGS IN THE CAPITAL OF THE COMPANY	36
2.5. HOLDERS OF SECURITY WITH SPECIAL CONTROL RIGHTS	36
2.6. CONTROL MECHANISM PROVIDED FOR A POSSIBLE SYSTEM OF EMPLOYMENT SHAREHOLDING WHEN THE CONTROL RIGHTS ARE NOT EXERCISED BY EMPLOYEES	37
2.7. AGREEMENTS BETWEEN SHAREHOLDERS KNOWN BY THE COMPANY THAT MAY RESULT IN RESTRICTIONS ON TRANSFER OF SHARES OR THE EXERCISE OF VOTING RIGHTS	37
2.8. RULES APPLICABLE TO THE APPOINTMENT AND REPLACEMENT OF MEMBERS OF THE BOARD OF DIRECTORS AND TO THE AMENDMENT OF THE BYLAWS OF THE COMPANY	37
2.9. POWERS OF THE BOARD, ESPECIALLY IN RELATION TO THE ISSUING OR REPURCHASE OF SHARES	37
2.10. AGREEMENTS SIGNED BY THE COMPANY MODIFIED OR TERMINATED IN CASE OF A CHANGE OF CONTROL	38
2.11. AGREEMENTS PROVIDING FOR COMPENSATION OF OFFICERS OR EMPLOYEES, IN CASE OF RESIGNATION, DISMISSAL WITHOUT AN ACTUAL AND SERIOUS CAUSE OR IF THEIR EMPLOYMENT IS TERMINATED DUE TO A PUBLIC TAKEOVER	38
III. REASONED OPINION OF THE CNOVA TRANSACTION COMMITTEE	38
IV. INTENTIONS OF THE BOARD OF DIRECTORS MEMBERS	44
V. REPORT OF THE INDEPENDENT EXPERT	47

*Translation for information purposes only.
In case of discrepancy between the French and the English version, the French version shall prevail.*

The Offer and this draft information memorandum in response remain subject to the review of the AMF

I. Presentation of the Offer

Pursuant to Title III of Book II and more specifically Article 233-1 1° of the AMF General Regulations, Casino, Guichard-Perrachon S.A.^[1], a *société anonyme* with a share capital of 171,319,066.38 euros, having its registered office located at 1, Cours Antoine Guichard – 42000 Saint-Etienne (France), registered to the Register of Commerce and Companies of Saint-Etienne under registration number 554 501 171, whose shares are admitted to trading on the regulated market of Euronext Paris (the “**Offeror**” or “**Casino**”), is making an irrevocable offer to the shareholders of Cnova N.V., a public limited liability company incorporated under the laws of the Netherlands, with as at the date of this draft offer document an aggregate issued and outstanding share capital of 42,670,639.90 euros, having its registered office located Schiphol Boulevard 273, 1118 BH Schiphol, The Netherlands, and registered with the Netherlands Trade Register under number 60776676 (“**Cnova**” or the “**Company**”), whose shares are admitted to trading on the regulated market of Euronext in Paris (“**Euronext Paris**”) under ISIN code NL0010949392, mnemonic “CNV” and on the NASDAQ Global Select Market (“**NASDAQ**”), ticker “CNV,” to purchase any and all of their ordinary shares, each having a nominal value of EUR 0.05 (the ordinary shares of Cnova being referred as to “**Shares**”) on the terms and conditions set forth below, at a price in euros equivalent to U.S. \$5.50 per Share, net to the seller in cash, calculated by using the WM/Reuters index spot exchange rate for euros per U.S. dollar at 5:00 p.m. (Paris time) on the business day following the closing of the offer, rounded down to the nearest thousandth euro; it being specified, that the global amount paid under each tender order will be rounded down to the nearest lesser euro cent^[2] (hereinafter referred to as the “**Offer**,” and, together with Casino’s separate, concurrent offer to purchase Shares in the United States of America from persons resident therein at a price of U.S. \$5.50 per Share, the “**Offers**”).

If, following the completion of the Offers, Casino and its affiliated companies own 95% or more of the issued and outstanding ordinary share capital (*geplaatst en uitstaand gewoon kapitaal*) of Cnova, then Casino, acting on its own or with its affiliated companies, would have the right, but not the obligation, to initiate, within three months following completion of the Offers, a buy-out procedure (*uitkoopprocedure* in accordance with Article 2:92a or 2:201a of the Dutch Civil Code (which is referred to herein as a “**Statutory Buy-Out**”) and/or a takeover buy-out procedure in accordance with Article 2:359c of the Dutch Civil Code (which is referred to herein as a “**Takeover Buy-Out**”) and, together with the Statutory Buy-Out, as a “**Buy Out**”) in order to acquire the Shares not tendered in the Offers and not held by Casino and its affiliated companies or Cnova at an equitable price that will be determined by the competent Dutch court.

¹ Casino is the ultimate holding company of the Casino group, a food distribution global actor, whose shares are listed on Euronext Paris under the number ISIN FR0000125585, indirectly controlled by Jean-Charles Naouri, who is also Chairman and Chief Executive Officer of Casino.

² This exchange rate is more specifically defined in Section 3.4 of the Offeror’s draft offer document.

*Translation for information purposes only.
In case of discrepancy between the French and the English version, the French version shall prevail.*

The Offer and this draft information memorandum in response remain subject to the review of the AMF

This fair price per Share will typically be equal to the consideration per Share offered in the Offers (if this price has been considered fair by the independent expert) unless there would be financial, business or other developments or circumstances that would justify a different price (including a reduction resulting from the payment of dividends or a higher price) in accordance with, respectively, Article 2:92a, paragraph 5 or 2:201a, paragraph 5 or Article 2:359c, paragraph 6 of the Dutch Civil Code. Similarly, if, following the completion of the Offers, Casino and its group companies own 95% or more of the issued and outstanding ordinary share capital (*geplaatst en uitstaand gewoon kapitaal*) of Cnova and 95% or more of the voting interests in Cnova, any minority shareholder would have the right, but not the obligation, to institute a court procedure pursuant to Article 2:359d of the Dutch Civil Code to require Casino to purchase its Shares against a fair price to be determined by the competent Dutch court, as described above. A minority shareholder would have to file such claim with the competent Dutch court within three months after the end of the acceptance period of the Offers.

The Offer is made in the context of the reorganization, completed on October 31, 2016 (the “**Reorganization Date**”) between Cnova Comércio Eletrônico S.A., a Brazilian private corporation (*sociedade anônima*), which is referred to herein as “**Cnova Brazil**” until now subsidiary of Cnova, and Via Varejo S.A., a Brazilian corporation (*sociedade anônima*), which is referred to herein as “**Via Varejo**”, CBD subsidiary as contemplated by the Reorganization Agreement whose main terms are defined in paragraph 1.3 below (the “**Reorganization**” and, together with the Offers, the “**Transactions**”).

Although the Offer is technically open to all holders of Shares, subject to section 3.8, including the RS, (as described in section 2.2.4 of the draft information memorandum of the Offeror), i.e. 344,507,048 Shares, the Offer will not be accepted by the Offeror and the following subsidiaries under the Offeror’s exclusive control, namely (i) Companhia Brasileira de Distribuição a sociedade anônima organized under the laws of Brazil, headquartered in the City of São Paulo, State of São Paulo, at Avenida Brigadeiro Luiz Antônio, 3142, Brazil, registered with the CNPJ/MF under number 47.508.411/0001-56 (“**CBD**”), which has agreed not to tender the Shares which it directly or indirectly holds into the Offer, and (ii) Almacenes Exito S.A., Almacenes Exito S.A., a company organized under the laws of Colombia, which is headquartered located at Envigado, Antioquia, Colombia registered with the Trade Office under number 890900608-9 (“**Exito**”) which has indicated that it does not intend to tender the Shares it directly holds into the Offer. The Offeror undertakes that it will not, and the Offeror will take all necessary measures to enforce its contractual and social rights in order to make sure that CBD and Exito to not, tender the Shares directly or indirectly held by such holders into the Offer. Taking into account the foregoing undertaking, the Offer will, as a practical matter, target only ordinary shares owned (indirectly or indirectly) by shareholders other than Casino, Exito and CBD.

The Offer does not target the following Cnova securities, which are not Shares:

- 314,940,097 special voting shares owned by a foundation (*stichting*) under Dutch law named Stichting Cnova Special Voting Shares (the “**Voting Foundation**”) described in Section 2.1 below, and which cannot be transferred, under the terms governing the Voting Foundation and the provisions of the special voting shares themselves, to any person other than Cnova; and
- 97,174,855 special voting shares and the 96,790,798 Distribution Preferred Shares acquired by Cnova within the Reorganization and with a view to having them cancelled.

*Translation for information purposes only.
In case of discrepancy between the French and the English version, the French version shall prevail.*

The Offer and this draft information memorandum in response remain subject to the review of the AMF

To the knowledge of the Offeror, there is no capital security or any other financial instrument or right which give or may give access, immediately or in the future, to the share capital or voting rights of the Company, except the Shares (including the restricted stock (the “**RS**”)), the special voting shares described in Section 2.1 of the Offeror’s draft offer memorandum, the deferred stock units (the “**DSU**”) described in Section 2.2.4 of the Offeror’s draft offer memorandum and the Distribution Preferred Shares defined below and under cancellation.

The Offer does not target DSUs as they are not currently transferable but targets, if applicable, a maximum number of 172,389 Shares that could be issued to the holders of DSUs governed by the *Sous Plan Qualifié Français* (as defined in section 2.2.4 of the Offeror’s draft offer memorandum), in case of death of their beneficiary. The Offer also targets all of the RS (which are Shares subject to transfer restrictions as described in section 2.2.4 of the Offeror’s draft offer memorandum), among which only two-thirds are transferrable during the Offer period. Apart from those Shares and RS, no new shares can be issued pursuant to the DSU and the Omnibus Incentive Plan (as defined in the Offeror’s draft offer memorandum) before November 19, 2018. The terms and conditions for the issuance of Shares under the *Sous Plan Qualifié Français* and the transferability of the RS are described in section 2.2.4 below

The Offer concerns a maximum number of 35,742,321 Shares, consisting of (i) the 344,507,048 existing Shares (including the RS), *less* (ii) the 308,937,116 Shares held by the Offeror and its controlled subsidiaries with which it is acting in concert (meaning CBD and Exit), *plus* (iii) the 172,389 Shares arising, as the case may be, from the DSU, governed by the “*Sous-Plan Qualifié Français*”.

JPMorgan Chase Bank, N.A. through its Parisian branch (“**J.P. Morgan**”), as the presenting bank for the Offer, acting on behalf of the Offeror, filed the draft offer document with the AMF on December 6, 2016. Pursuant to the provisions of Article 231-13 of the AMF General Regulations, J.P. Morgan guarantees the content and the irrevocable nature of the undertakings given by the Offeror in connection with the Offer.

Casino is also making a concurrent, separate offer to purchase any and all Shares held by persons resident in the United States (“**U.S. Holders**”) at a price of U.S. \$ 5.50 per Share to all holders of Shares resident in the United States of America (the “**U.S. Offer**”). U.S. Holders may only tender their Shares to the U.S. Offer.

The U.S. Offer is made in the United States; where the NASDAQ is located, principal trading market of the Shares. Pursuant to requirements of U.S. law, the U.S. Offer must remain open for at least 20 business days, the offer is centralized and any U.S. Holder is permitted to withdraw Shares previously tendered until expiration of the U.S. Offer. So that shareholders are treated equally in the U.S. Offer and the Offer (which is required by U.S. regulations), by way of derogation from articles 233-11 and following of the General Regulation of the AMF and as explained in more details in part III of the Offeror’s draft memorandum, the Offer (i) will last 20 trading days, (ii) be centralized by Euronext Paris and (iii) the sale orders will be revocable at any time until the last day of the Offer.

Holders of Shares who are not resident in France or in the United States may tender their Shares in the Offer as long as the laws and regulations applicable to such holders authorize them to do so and under their responsibility.

*Translation for information purposes only.
In case of discrepancy between the French and the English version, the French version shall prevail.*

The Offer and this draft information memorandum in response remain subject to the review of the AMF

1.1. Context of and rationale for the transaction

1.1.1. Presentation of the Company and background of the transaction

The following summarizes the significant events that led to the signing of the Reorganization Agreement (as defined below) and to the launch of the Offers, without pretending to represent the exhaustiveness of the exchanges between the concerned parties.

Cnova was incorporated on May 30, 2014, as a public limited liability company (*naamloze vennootschap*) organized under the laws of the Netherlands. In July 2014, Cnova completed the reorganization of the eCommerce businesses of Casino and its affiliated entities in France and Brazil, including CBD and Via Varejo. Following the completion of this initial reorganization, Cnova owned, directly or indirectly, substantially all of the assets that were used in the non-food eCommerce businesses of Casino, CBD and Via Varejo. On November 25, 2014, Cnova completed the initial public offering of its Shares, which began trading on NASDAQ on that date. On January 23, 2015, the Shares began trading on Euronext Paris under the ticket symbol “CNV”, with Morgan Stanley & Co. LLC, J.P. Morgan Securities LLC, Merrill Lynch, Pierce, Fenner & Smith Incorporated, Credit Suisse Securities (USA) LLC and Deutsche Bank Securities Inc. acting as *bookrunners*, and BNP Paribas Securities Corp., HSBC Securities (USA) Inc., Natixis Securities Americas LLC and SG Americas Securities LLC acting as co-manager of the offer.

The senior management and the boards of directors of Casino and Cnova actively monitor and assess developments in the online retail industry, as well as economic and business trends in Brazil and France, which are the primary markets in which Cnova used to compete. In addition, the senior management of Via Varejo and its board of directors actively monitor and assess developments in the Brazilian brick-and-mortar retail industry, as well as overall economic and business trends in Brazil. Casino, as the controlling shareholder of its group of affiliated companies (the “**Casino Group**”), periodically reviews the performance of the affiliated entities within its affiliated companies, including Cnova and Via Varejo, and regularly assesses opportunities to improve the competitive position and business strategy of the Casino Group, as well as to maximize operating synergies among the Casino Group companies.

Throughout late December of 2015 and January and February of 2016, representatives of Casino, including Jean-Yves Haagen, Group General Counsel and Luis Enrique Devis, Director of Corporate Development and Holdings – Latam, and representatives of Cnova, including Stéphane Brunel (then Deputy Chief Financial Officer of Cnova, at present Chief Financial Officer of Cnova), and Steven Geers, General Counsel of Cnova, evaluated potential transaction structures that would permit the combination of Cnova’s Brazilian eCommerce business with Via Varejo. To assist in the legal aspects of this review, Casino and Cnova engaged Darrois Villey Maillot Brochier (“**Darrois**”), NautaDutilh N.V. (“**NautaDutilh**”), Trindade Sociedade de Advogados, (“**Trindade**”), Lefosse Advogados (“**Lefosse**”), and Wachtell, Lipton, Rosen & Katz, (“**Wachtell Lipton**”), as legal advisors.

*Translation for information purposes only.
In case of discrepancy between the French and the English version, the French version shall prevail.*

The Offer and this draft information memorandum in response remain subject to the review of the AMF

On March 3, 2016, the Cnova board of directors met telephonically, discussed a broad outline of the proposed transactions, and met telephonically with members of Cnova's management and representatives of BNP Paribas, financial advisors to Cnova, and a representative of Eight Advisory France S.A.S. ("**Eight Advisory**"). During this meeting, the following Cnova's board of directors members determined that, in light of the relationships between Cnova, CBD, Via Varejo and their controlling shareholder, Casino, each of the following members of Cnova's board of directors recused themselves from participating in any further deliberations and decision making in connection with the Transactions: Peter Estermann, Didier Lévêque, Ronaldo Iabrudi do Santos Pereira, Eleazar de Carvalho Filho, Yves Desjacques, Antoine Giscard d'Estaing and Arnaud Strasser. The Cnova board of directors then approved the formation of a Transaction Committee for purposes of evaluating, negotiating and entering into agreements in connection with the Transactions, which is referred to herein as the "**Cnova Transaction Committee**", consisting of Silvio J. Genesini, Bernard Oppetit and Cnova's chief executive officer, Emmanuel Grenier. The other members of the Cnova board of directors then left the meeting.

The Cnova Transaction Committee subsequently discussed with representatives of management and BNP Paribas, the strategic rationale of a series of transactions that would combine the business of Via Varejo and Cnova Brazil, including, among other things, the operational difficulties experienced by Cnova Brazil and refocusing Cnova on the Cdiscount business in France, where Cdiscount has a market-leading position and a demonstrated capacity for expanding market share. The Cnova Transaction Committee retained Freshfields Bruckhaus Deringer LLP ("**Freshfields**"), as independent counsel to the Cnova Transaction Committee, and Eight Advisory as independent valuation expert to the Cnova Transaction Committee in connection with its evaluation of the proposed Transactions. In addition to representatives of the aforementioned financial advisors, representatives of Darrois, Lefosse, NautaDutilh, Trindade and Wachtell Lipton, were also present at the meeting. At the conclusion of this meeting, the Cnova Transaction Committee directed Cnova's management to explore further the proposed Transactions and to develop a review of any other strategic alternatives available to Cnova, to be presented to the Cnova Transaction Committee.

On March 9, 2016 and March 15, 2016, the Cnova Transaction Committee met telephonically with members of Cnova's management and representatives of BNP Paribas. Representatives of Freshfields also participated in the calls. During these meetings, Stéphane Brunel, presented a number of strategic alternatives to the Cnova Transaction Committee, including (a) the possibility of a sale of Cnova Brazil to an unaffiliated third party, (b) the possibility of an exchange offer by Via Varejo in connection with Via Varejo's acquisition of Cnova Brazil, (c) the sale of Cnova Brazil to Via Varejo for cash, together with a possible share buyback by Cnova or a special dividend of the cash proceeds of the transaction, (d) a tender offer by Casino for Shares followed by an indirect merger of Cnova Brazil into Via Varejo and the cancellation of Via Varejo's interest in Cnova and (e) the indirect merger of Cnova Brazil into Via Varejo, followed by a tender offer by Casino for Shares and a cancellation of Via Varejo's interest in Cnova.

*Translation for information purposes only.
In case of discrepancy between the French and the English version, the French version shall prevail.*

The Offer and this draft information memorandum in response remain subject to the review of the AMF

During these meetings, the Cnova Transaction Committee discussed the advantages and disadvantages of each of these potential strategic alternatives. The Cnova Transaction Committee eliminated the possibility of a sale to a third party outside the CBD and its group of affiliated companies because of the loss of brands and other intellectual property licensed from CBD and Via Varejo would be likely to destroy value in the business. The Cnova Transaction Committee also eliminated the possibility of an exchange offer by Via Varejo in consideration of its acquisition of Cnova Brazil because of the timing implications and legal complexities involved in conducting an exchange offer in the United States, which Via Varejo would be required to register under the U.S. Securities Act of 1933, as amended, and which would result in Via Varejo having ongoing reporting obligations in the United States under the U.S. Securities Exchange Act of 1934, as amended. The Cnova Transaction Committee determined not to pursue a cash sale of Cnova Brazil to Via Varejo because it was informed by Cnova's management that Via Varejo would be unable to fund adequate cash consideration. After extensive discussion, the Cnova Transaction Committee ultimately determined that the possibility of a reorganization of the Cnova Brazil business within Via Varejo, by means of an indirect merger, followed by a cancellation of Via Varejo's interest in Cnova, together with a tender offer by Casino for Shares, would be the best available strategic alternative for Cnova and Cnova Brazil. The Cnova Transaction Committee preferred this alternative because of the significant operational synergies between Cnova Brazil and Via Varejo, the simplification of the Cnova holding structure, which would focus entirely on Cdiscount following the completion of the transaction, and the relatively expeditious timeline for completing such a transaction.

In determining to require that Casino undertakes a tender offer for Shares, conditioned only on completion of the proposed reorganization, the Cnova Transaction Committee noted that, as a result of the completion of the proposed reorganization, the business profile of Cnova would be significantly altered and investors may prefer to receive a fixed cash payment for their Shares, rather than retaining an interest in Cnova. The Cnova Transaction Committee also noted its expectation that the liquidity of Shares on NASDAQ and Euronext Paris would be significantly reduced if the Offers were successful. The Cnova Transaction Committee stated its expectation that the price to be offered by Casino in the Offers would reflect full and fair value for the Shares. Finally, in connection with the potential transaction, BNP Paribas discussed historical trading prices per share for Shares and target prices for Shares based on publicly available equity research estimates.

On March 25, 2016, the Cnova Transaction Committee met telephonically with members of Cnova's management and representatives of BNP Paribas. Representatives of Freshfields also participated in the call, together with representatives of Darrois and NautaDutilh. The meeting participants were provided with a preliminary draft of the valuation report of BNP Paribas, which report included preliminary valuations of Cnova Brazil, Cdiscount and Cnova on a consolidated basis. After reviewing these preliminary valuations, the members of the Cnova Transaction Committee indicated their belief that, based on the Cnova business plan and the financial advisors' extrapolation period projections, the valuation of Cnova on a per share basis should reflect a very significant premium to the market price of Shares.

*Translation for information purposes only.
In case of discrepancy between the French and the English version, the French version shall prevail.*

The Offer and this draft information memorandum in response remain subject to the review of the AMF

On March 27, 2016, representatives of Casino and Cnova sent a draft of a non-binding memorandum of understanding with respect to the proposed reorganization to members of Via Varejo's management and Via Varejo's legal advisors. The draft memorandum of understanding provided for Cnova Brazil to be reorganized within Via Varejo through a series of corporate transactions, pursuant to which Via Varejo's approximately 21.9% indirect interest in Cnova would be cancelled. The draft memorandum of understanding provided for indemnification obligations of Cnova, the amount of which, if payable, would be reduced by 21.9% in respect of the portion of any loss corresponding to Via Varejo's level of ownership in Cnova prior to the completion of the transaction. The draft memorandum of understanding also provided that Cnova would not have any liability for indemnification in respect of conduct occurring prior to October 17, 2013, the date on which the Casino Group initially acquired control of Cnova Brazil from Via Varejo.

On March 31, 2016 and April 1, 2016, a representative of Via Varejo met with Mr. Devis, Rafael Russowsky and Mr. Brunel, together with representatives of Darrois, Lefosse, NautaDutilh, Trindade and Wachtell Lipton, to discuss the draft memorandum of understanding. The parties discussed the draft memorandum of understanding and, in particular, the approach to indemnification set forth therein. The parties discussed whether the limitation on Cnova's indemnification obligations in respect of Via Varejo's pre-transaction ownership might be acceptable to Via Varejo. The parties also discussed that Via Varejo would not likely accept a limitation of Cnova's indemnification obligations in respect of the period prior to Casino Group obtaining control of the operations of the Cnova Brazil business.

On April 13, 2016, the Cnova Transaction Committee met with members of Cnova's management, representatives of BNP Paribas and representatives of Eight Advisory at BNP Paribas's office in London. A representative of Freshfields also participated in the meeting, together with representatives of Darrois and NautaDutilh. Mr. Brunel explained that, based on discussions in prior meetings and updated market data, BNP Paribas had revised its draft valuation report to reflect revised preliminary valuations of Cnova Brazil, Cdiscount and Cnova on a consolidated basis. At the meeting, BNP Paribas discussed these preliminary valuations, including the ranges of equity value per share that such preliminary valuations implied.

On April 18, 2016, representatives of Casino and Cnova sent a revised draft of the memorandum of understanding with respect to the proposed reorganization to members of Via Varejo's management and Via Varejo's legal advisors, reflecting Casino and Cnova's positions with respect to the proposed transaction.

On April 28, 2016, in response to speculation in the press related to a potential transaction involving Via Varejo and Cnova Brazil, Via Varejo and Cnova issued a press release confirming that the companies were reviewing, together with certain of their affiliates, the viability of and interest in a potential reorganization in which Cnova Brazil would be reorganized within Via Varejo.

On May 3, 2016, the Cnova Transaction Committee met in Paris, joined by representatives from Cnova management, representatives of Casino, BNP Paribas, Eight Advisory and Freshfields, with representatives of Darrois and NautaDutilh joining by telephone. During this meeting, the members of the Cnova Transaction Committee reiterated their support for the further exploration of the proposed Transactions and determined that the Cnova Transaction Committee required that the price offered by Casino in the Offers be US\$5.50 per Share in order for the Cnova Transaction Committee to be able to support the proposed Reorganization.

*Translation for information purposes only.
In case of discrepancy between the French and the English version, the French version shall prevail.*

The Offer and this draft information memorandum in response remain subject to the review of the AMF

On May 5, 2016, in response to continued rumors in the press relating to a potential transaction, at the instruction of Via Varejo's management and the Cnova Transaction Committee, Cnova's and Via Varejo's respective legal advisors discussed a short-form version of the draft memorandum of understanding with respect to the proposed reorganization, which would set forth the economic terms of the proposed reorganization and an agreed-upon valuation range for Cnova Brazil for purposes of the proposed reorganization, and would defer negotiation of other provisions of a definitive Reorganization Agreement, including the content of the representations and warranties, interim operating covenants and indemnification provisions, to a later date. Via Varejo and the Cnova Transaction Committee instructed their advisors to proceed with the negotiation of such a short-form non-binding memorandum of understanding.

On May 10, 2016, the audit committee of the Casino board of directors, which is referred to herein as the "**Casino audit committee**" and the "**Casino board**", respectively, met with members of Casino's management, representatives of Rothschild & Co Banque ("**Rothschild**"), and Crédit Agricole Corporate & Investment Bank ("**CACIB**"), financial advisors to Casino, as well as representatives of Messier Maris & Associés ("**MMA**"), special financial advisor to the Casino audit committee, to review the terms of the proposed Reorganization and the Offers. Representatives of Darrois, legal advisor to Casino and Cnova, also attended the meeting. Representatives of Casino's management and of Darrois gave the members of the Casino audit committee an overview of the proposed Transactions, of the proposed non-binding memorandum of understanding and of the commitment letter whereby Casino would undertake to Cnova that, should the proposed reorganization be completed, Casino would launch tender offers in the United States and outside of the United States, with an offer price of US\$5.50 per Share. Representatives of Rothschild and CACIB presented their conclusions, as set forth in their preliminary joint valuation report, reflecting valuations of Cnova Brazil, Cdiscount and Cnova on a consolidated basis. A representative of MMA then stated that, as of such date and based upon and subject to the assumptions made, procedures followed, matters considered and qualifications and limitations described in the MMA valuation report, the analysis and the results presented by the Casino financial advisors in the Casino financial advisors valuation report were consistent with the analysis performed by MMA and that the Casino financial advisors' analysis had been conducted in accordance with the methods upon which MMA has no comments other than those summarized in the MMA report. On this basis, the Casino audit committee determined to recommend the terms of the proposed Transactions, including the terms of the proposed reorganization set forth in the non-binding memorandum of understanding, and the tender offers to the full Casino board.

*Translation for information purposes only.
In case of discrepancy between the French and the English version, the French version shall prevail.*

The Offer and this draft information memorandum in response remain subject to the review of the AMF

On May 11, 2016, Via Varejo's board of directors, which is referred to herein as the "**Via Varejo board**", met and determined, in accordance with Via Varejo's policy for related party transactions, to create a special committee composed of a majority of independent directors, in order to analyze the terms and conditions of the proposed reorganization, to negotiate the final Reorganization Agreement (as it is defined below) and to issue a recommendation to the Via Varejo board regarding the proposed Reorganization and the new operational agreement to be entered into between CBD and Via Varejo in connection with the proposed Reorganization. The Via Varejo board appointed Alberto Guth, Renato Carvalho do Nascimento and Christophe Hidalgo to the newly formed Via Varejo special committee, which is referred to herein as the "**Via Varejo special committee**".

Also on May 11, 2016, pursuant to the shareholders agreement in place among the shareholders of Via Varejo a the representatives of CBD and of the CB Group (a group of shareholders of Via Varejo that is unaffiliated with Casino, CBD and Cnova, consisting of Mr. Michael Klein and the companies EK VV Limited, Bahia VV RK Limited, Bahia VV NK Limited, Altara RK Investments Limited and Altara NK Investments Limited, collectively holding approximately 27.3% of the outstanding share capital of Via Varejo as of September 29, 2016) approved a shareholders' resolution. Pursuant to the shareholders' resolution: (i) CBD committed to not exercise its voting rights at the meeting of Via Varejo's shareholders in connection with the proposed reorganization, in order to enhance the independence of the approval of the Via Varejo shareholders by effectively granting Via Varejo's minority shareholders the power to approve or reject the proposed reorganization; and (ii) the CB Group committed to vote in favor of the proposed reorganization at such meeting provided that the Via Varejo special committee unanimously recommends such a vote.

Also on May 11, 2016, CBD's board of directors met and decided, in compliance with CBD's policy for related party transactions, to create a special committee composed of a majority of independent directors, in order to analyze the terms and conditions of the proposed Transactions and issue a recommendation to CBD's board of directors regarding (i) the vote to be cast by CBD at the meeting of Cnova's shareholders in connection with the proposed reorganization; (ii) whether or not CBD would agree not to tender its Shares into the Offers; and (iii) the terms and conditions of the new operational agreement to be entered into between CBD and Via Varejo in connection with the completion of the proposed reorganization. The CBD board of directors named board members Eleazar de Carvalho Filho, Maria Helena S. F. Santana and Luiz Aranha Corrêa do Lago as the members of the CBD special committee (the "**CBD special committee**").

Also on May 11, 2016, the Cnova Transaction Committee met telephonically with members of Cnova's management, representatives of BNP Paribas and representatives of Eight Advisory. Representatives of Freshfields also participated in the call, together with representatives of Darrois and NautaDutilh. A representative of BNP Paribas presented a revised draft valuation report based on current market information. The representative of BNP Paribas discussed with the Cnova Transaction Committee these updated preliminary valuations, including the ranges of equity value per share that such updated preliminary valuations implied. Further, Eight Advisory also presented its preliminary valuation report, reflecting valuations for Cnova Brazil, Cdiscount and Cnova on an unconsolidated basis (after taking account of overhead and other operational holding costs). The representatives of Casino also confirmed that Casino had agreed to launch a tender offer at a price of US\$5.50 per Share should the proposed reorganization be completed, as set forth in a draft commitment letter from Casino to the Cnova Transaction Committee. The Cnova Transaction Committee thereafter resolved to authorize Cnova's management to execute the non-binding memorandum of understanding and to enter into negotiations with respect to definitive transaction documentation on the basis of the memorandum of understanding.

*Translation for information purposes only.
In case of discrepancy between the French and the English version, the French version shall prevail.*

The Offer and this draft information memorandum in response remain subject to the review of the AMF

Later on May 11, 2016, after the meetings of the Via Varejo board and the Cnova Transaction Committee, Casino delivered a commitment letter to Cnova regarding the Offers to be undertaken following completion of the proposed Reorganization and Cnova and Via Varejo executed the non-binding memorandum of understanding regarding the proposed reorganization. Following the execution of these agreements, Via Varejo, Cnova and Casino issued press releases disclosing the proposed Transactions and the execution of the non-binding memorandum of understanding.

On May 20, 2016, the Via Varejo special committee held a conference call to discuss the scope of work that would be carried out by the Via Varejo special committee in connection with the evaluation of the proposed reorganization and the engagement of independent external financial and legal advisors. They were joined by Peter Estermann, chief executive officer of Via Varejo, and André Rizk, general counsel of Via Varejo. The Via Varejo special committee later engaged Banco Santander (Brasil) S.A. (“**Santander**”) as its external and independent financial advisor and Yazbek Advogados (“**Yazbek**”), and Campos Mello Advogados, (“**Campos Mello**”), as independent legal advisors.

On June 8, 2016, the Cnova Transaction Committee met in São Paulo, Brazil, and was joined in person by Steven Geers, general counsel of Cnova, Messrs. Devis and Russowsky, representatives of Casino, and representatives of Trindade. Mr. Brunel and representatives of BNP Paribas and Freshfields attended the meeting by telephone. During this meeting, the Cnova Transaction Committee received an update on the ongoing negotiations with the Via Varejo special committee and its advisors.

On June 20, 2016, the Via Varejo special committee met by videoconference, together with a representative of Campos Mello. At this meeting, the Via Varejo special committee determined the scope of due diligence to be undertaken in connection with the proposed reorganization; (i) the engagement of a consultant to carry out financial and accounting due diligence with respect to Cnova Brazil; and (ii) the engagement of Davis Polk & Wardwell LLP (“**Davis Polk**”), as special counsel for matters of U.S. law, in particular with respect to certain litigation then-pending against Cnova and in connection with the negotiation and drafting of a definitive Reorganization Agreement.

On June 21, 2016, the Via Varejo special committee and its legal advisors met in São Paulo, and were joined by André Rizk, then-general counsel of Via Varejo, Messrs. Devis and Russowsky and representatives of Trindade and Lefosse. During this meeting, the Via Varejo special committee received an update with respect to the ongoing investigation of certain accounting matters with respect to Cnova Brazil and related litigation.

On June 23, 2016, the Via Varejo special committee, Campos Mello and Yazbek met in São Paulo, and were joined by Messrs. Devis and Russowsky and by representatives of Trindade and Lefosse, to discuss the terms of the draft Reorganization Agreement, particularly the proposed limitations on Cnova’s indemnification obligations. The members of the Via Varejo special committee expressed their continued view that Cnova should indemnify Via Varejo with respect to conduct arising prior to the Casino Group obtaining control over the operations of the Cnova Brazil business. The members of the Via Varejo special committee and the representatives of Casino also discussed whether or not Cnova’s indemnification obligations under the Reorganization Agreement would be subject to a cap. The members of the Via Varejo special committee indicated that the concept of a cap would be acceptable, subject to specified exceptions and if the cap was of a large enough amount.

*Translation for information purposes only.
In case of discrepancy between the French and the English version, the French version shall prevail.*

The Offer and this draft information memorandum in response remain subject to the review of the AMF

On July 6, 2016, legal advisors to Via Varejo's special committee provided Casino's and Cnova's legal advisors with a revised draft of the Reorganization Agreement. Among other provisions, the draft provided that Casino would be a party to the Reorganization Agreement as a guarantor of Cnova's obligations thereunder, removed limitations on indemnification and expanded the representations and warranties to be made by Cnova in respect of Cnova Brazil's business. The revised draft also provided for an adjustment to the balancing payment based on a full reconciliation of the balance sheet of Cnova Brazil at the completion of the Reorganization.

On July 12, 2016, the Via Varejo special committee and its legal advisors met in São Paulo with Mr. Devis and representatives of Trindade and Lefosse. The parties discussed the status of the negotiation of the draft Reorganization Agreement and the schedule for the finalization of Cnova's restated financial statements. The parties further discussed the terms of the draft Reorganization Agreement that remained under negotiation. In particular, the parties discussed whether Casino would be a party to the Reorganization Agreement; whether the Reorganization Agreement would include a balancing payment adjustment; whether Cnova would be responsible to Via Varejo for indemnification with respect to conduct that occurred prior to the Casino Group obtaining control over the business of Cnova Brazil; and whether other indemnification limitations should be included in the Reorganization Agreement. These positions were discussed among Mr. Devis, the members of the Via Varejo special committee and their respective advisors. The status of Via Varejo's due diligence and the draft operational agreement were also discussed.

On July 15, 2016, the Cnova Transaction Committee met by telephone, together with members of Cnova's and Casino's management, the legal advisors to Cnova and Casino and representatives of Freshfields, the legal advisor to the Cnova Transaction Committee. A representative of Trindade updated the members of the Cnova Transaction Committee on the key issues raised by Via Varejo's most recent draft of the Reorganization Agreement (as it is defined below) as well as the key points of disagreement discussed during the July 12, 2016 meeting between Cnova's legal advisors and the legal advisors to the Via Varejo special committee. In particular, the members of the Cnova Transaction Committee were informed that the Via Varejo special committee was unlikely to accept an exclusion from indemnification for items occurring prior to the Casino Group gaining control over the business of Cnova Brazil in October 2013. Mr. Brunel discussed with the members of the Cnova Transaction Committee the challenges posed by Via Varejo's request for a balancing payment adjustment and the various methods of making such an adjustment. The Cnova Transaction Committee requested that Cnova's financial advisors undertake a review of possible balancing payment adjustment methodologies in order to make a recommendation on a methodology that would be fair to both Cnova and Via Varejo. The members of the Cnova Transaction Committee and the advisors also discussed alternative approaches that might allow the proposed reorganization to proceed without a balancing payment adjustment, including the possibility of adopting a locked box mechanism.

*Translation for information purposes only.
In case of discrepancy between the French and the English version, the French version shall prevail.*

The Offer and this draft information memorandum in response remain subject to the review of the AMF

During the morning of July 25, 2016, the members of the Cnova Transaction Committee met telephonically, together with representatives of Freshfields, representatives of Cnova's and Casino's management, representatives of Eight Advisory, representatives of BNP Paribas and representatives of Cnova's and Casino's legal advisors, including Darrois, Lefosse, NautaDutilh, Trindade and Wachtell Lipton. A representative of BNP Paribas presented an overview of possible balancing payment adjustment methodologies, noting the advantages and disadvantages of the various methodologies to Cnova. After a detailed discussion of these alternatives, the Cnova Transaction Committee instructed management and the advisors to negotiate a balancing payment adjustment based on differences in the working capital and net debt positions of Cnova Brazil as compared to forecasted targets as of the applicable Reorganization Date.

During the afternoon of July 25, 2016, Messrs. Genesini, Devis and Russowsky, together with representatives of Darrois, Lefosse, Trindade, NautaDutilh and Wachtell Lipton met with the Via Varejo special committee, together with representatives of Campos Mello, Yazbek and Davis Polk to discuss the principal open terms of the draft Reorganization Agreement. The discussions included the possibility of an adjustment to the cash portion of the consideration to be paid by Via Varejo to Cnova in the proposed reorganization, which adjustment would be based on Cnova Brazil's working capital and net debt positions, and the limitations on Cnova's indemnification obligations under the draft Reorganization Agreement. Later on July 25, 2016, following this meeting, Cnova's legal advisors delivered a marked-up draft of the draft Reorganization Agreement to Via Varejo's legal advisors, reflecting the negotiating positions that had been described to the Via Varejo special committee and its legal advisors earlier that day.

Also on July 25, 2016, the Via Varejo special committee engaged the law firm De Brauw Blackstone Westbroek, for support in connection with the proposed reorganization with respect to matters of Dutch law.

On July 26, 2016, Messrs. Devis, Russowsky and Brunel, representatives of Via Varejo, representatives of BNP Paribas, and representatives of Santander spoke by telephone and discussed possible approaches to adjusting the amount of the cash consideration to be paid by Via Varejo to Cnova in the proposed reorganization, including the economic basis of the target net debt and working capital against which any such adjustment would be measured. The representatives of Santander indicated that, subject to review and confirmation by Santander and the members of the Via Varejo special committee of the projections of Cnova Brazil's working capital and net debt position through the likely Reorganization Date, the concept of a working capital and net debt adjustment would be acceptable to Via Varejo.

On July 27, 2016, the Casino audit committee met with members of Casino's management and representatives from Darrois to discuss, among other things, the request of the Via Varejo special committee that Casino execute the draft Reorganization Agreement, for the purpose of guaranteeing Cnova's obligations thereunder. Representatives of Casino's management and representatives of Darrois were present by phone. After discussing the matter with members of Casino's management and Casino's legal advisors, the Casino audit committee agreed with management's recommendation, but that Casino offer to support Cnova's indemnification obligations through the provision of a separate limited guarantee, up to a maximum amount of U.S. \$60 million, instead of Casino being a party to the Reorganization Agreement.

*Translation for information purposes only.
In case of discrepancy between the French and the English version, the French version shall prevail.*

The Offer and this draft information memorandum in response remain subject to the review of the AMF

On July 28, 2016, the Via Varejo special committee met with Campos Mello and Yazbek in order to discuss the pending issues concerning the Reorganization Agreement, including the guarantee sought from Casino and the balancing payment adjustment mechanism and indemnity provision.

On July 28, 2016, the members of the Cnova Transaction Committee, together with representatives of Cnova management, Messrs. Devis and Russowsky and representatives of Darrois, Lefosse, NautaDutilh, Trindade and Wachtell Lipton, held a call with representatives of the Via Varejo special committee and their legal advisors from Campos Mello and Yazbek. Casino and Cnova's legal advisors explained that Casino preferred not to be a party to the draft Reorganization Agreement, as well as the view of Casino and Cnova that, in light of the substantial assets and continuing business of Cnova following the completion of the proposed transaction, no guarantee from Casino should be necessary because Cnova would have adequate assets to support its obligations following closing. The parties also discussed the scope of Cnova's indemnification obligations and the balancing payment adjustment mechanism. The Via Varejo special committee agreed to review the latest draft of the Reorganization Agreement provided by Cnova. The representatives of Casino indicated that, in light of the importance of the guarantee to the Via Varejo special committee, Casino's board would discuss the matter.

On July 29, 2016, the Casino board discussed Via Varejo's request for a guarantee and approved, among other things, the provision to Cnova of a separate limited guarantee (or, if so determined, a letter of credit from an internationally recognized banking institution), up to a maximum amount of US\$60 million, which could be used to Cnova's indemnification obligations under the draft Reorganization Agreement. The Casino Board also received updated information about the progress of the negotiations and the different contracts to which Casino would be a party as part of the Transactions.

On July 30, 2016, the Cnova Transaction Committee held a meeting by telephone joined by representatives of Cnova management, of Eight Advisory and the committee's legal advisors, and also was attended by representatives of BNP Paribas, during which BNP Paribas and Eight Advisory provided their respective updated preliminary analyses on the valuation of Cnova, Cnova Brazil and Cdiscount. The committee reviewed and discussed the updated preliminary analyses and provided feedback.

Also on July 30, 2016, the Via Varejo special committee and its legal advisors held a conference call in order to resolve on the proposals received from Cnova, in light of the discussions held on the previous days. The Via Varejo special committee concluded that such proposals were, in concept, consistent with the interests of Via Varejo's shareholders and, therefore, resolved to accept the concept of a balancing payment adjustment and Cnova's proposal that, instead of Casino being party to the proposed reorganization, Casino would provide support for Cnova's indemnification obligations through alternate means including a guarantee. The Via Varejo special committee then discussed the pending issues concerning the indemnity provision contained in the draft Reorganization Agreement, including the scope of the limitations thereon.

*Translation for information purposes only.
In case of discrepancy between the French and the English version, the French version shall prevail.*

The Offer and this draft information memorandum in response remain subject to the review of the AMF

On August 3, 2016, the Via Varejo special committee held a conference call with their legal advisors in order to discuss their additional comments to the draft Reorganization Agreement. On the same date, representatives of Davis Polk delivered a marked-up draft of the Reorganization Agreement to representatives of Wachtell Lipton, reflecting the outcome of the parties' conversation on July 28, 2016.

On August 4, 2016, the Via Varejo special committee met with representatives of Santander, Campos Mello and Yazbek, in order to analyze the draft financial analysis report prepared by Santander and the adjustments made in view of Cnova's recent restatement of its financial statements following the conclusion of its internal investigation into certain accounting concerns at Cnova Brazil, and the revised business plans of Cnova and Cnova Brazil. The Via Varejo special committee posed several questions to Santander, including with respect to synergies and the adjustments made due to the results of an accounting investigation at Cnova Brazil.

Also on August 4, 2016, representatives of Davis Polk, Campos Mello and Yazbek met with Mr. Geers, general counsel of Cnova, and representatives of Darrois, Lefosse, NautaDutilh, Trindade and Wachtell Lipton to negotiate the legal terms of the draft Reorganization Agreement. The members of the Via Varejo special committee and Messrs. Devis and Russowsky also joined the meeting by telephone. During this meeting, the parties agreed that Cnova would agree to indemnify Via Varejo for certain liabilities of Cnova Brazil related to consumer claims and labor matters, as more specifically set forth in the Reorganization Agreement. The parties also agreed on which components of Cnova's indemnification obligations would be subject to the aggregate cap on liability and that Cnova would place a portion of the cash to be received at the completion of the proposed reorganization into escrow, in support of Cnova's indemnification obligations to Via Varejo under the draft Reorganization Agreement. Following this meeting, Wachtell Lipton circulated a revised draft of the Reorganization Agreement to the Via Varejo special committee's legal advisors.

On August 5, 2016, Mr. Devis and the members of the Via Varejo special committee engaged in a discussion of the financial terms of the proposed reorganization. They agreed that the proposed Reorganization would estimate an equity value of Cnova equal to approximately U.S. \$2.2 billion and an equity value of Cnova Brazil equal to approximately U.S. \$489.0 million. Based on these valuations and on the outstanding principal and interest on existing loan agreements existing loan agreements between Cnova Brazil, Cnova and Cnova Finança, a *besloten vennootschap met beperkte aansprakelijkheid* organized under the law of the Netherlands ("**Cnova Finança**") equal to approximately U.S. \$156.0 million, the parties agreed that Via Varejo would make a cash payment to Cnova in the amount of approximately R\$16.5 million. These amounts were within the valuation ranges set forth in the non-binding memorandum of understanding and were agreed on the basis of an exchange rate of 3.2763 R\$/U.S. \$, as set forth in the Reorganization Agreement.

Over the course of August 5, 6 and 7, 2016, the parties and their legal advisors finalized the remaining terms of the draft Reorganization Agreement, including the remaining open points with respect to Cnova's indemnification obligations and the limitations on such obligations pursuant to the Reorganization Agreement.

*Translation for information purposes only.
In case of discrepancy between the French and the English version, the French version shall prevail.*

The Offer and this draft information memorandum in response remain subject to the review of the AMF

During the morning of August 8, 2016, CBD's board of directors met, and the CBD special committee submitted its considerations and conclusions to the CBD board of directors, including its unanimous recommendation in favor of (i) CBD's vote in favor of approval of the Reorganization at the extraordinary general meeting of Cnova shareholders ("**Cnova EGM**"); and (ii) CBD agreement not to tender its Shares in the Offers. In light of the favorable recommendation of CBD's special committee, and considering that Casino submitted a commitment letter to CBD, pursuant to which Casino has granted CBD certain governance and liquidity rights in relation to the interest held by CBD in Cnova, CBD's board of directors resolved that CBD shall vote in favor of approval of the Reorganization at the Cnova EGM and that CBD shall not tender its Shares in the Offers. CBD's board of directors also confirmed its prior resolution that CBD shall not exercise its voting rights with respect to the Reorganization at the extraordinary general meeting of the Via Varejo shareholders.

Also during the morning of August 8, 2016, a meeting of Via Varejo's Board of Directors was held at which representatives of Santander, Campos Mello and Yazbek were present, in which the Via Varejo special committee submitted its considerations and conclusions to Via Varejo's Board of Directors, as well as its unanimous recommendation in favor of the implementation of the proposed reorganization and the execution of the proposed Reorganization Agreement. In light of the Via Varejo's special committee's favorable recommendation, Via Varejo's Board of Directors resolved to approve (i) the execution of the draft Reorganization Agreement with Cnova Brazil and Cnova NV, as well as (ii) the convening of an extraordinary general shareholders meeting in order to submit the proposed reorganization to the approval of, holders of Via Varejo's common and preferred shares. The Via Varejo's Board of Directors further approved the submission of Via Varejo's new stock option compensation plan to Via Varejo's shareholders for approval. The Via Varejo Board also approved, following the recommendation of the Via Varejo special committee, the execution of the new operational agreement between CBD and Via Varejo. Following this meeting, CBD and Via Varejo executed the new operational agreement (the "**Reorganization Agreement**").

Later on August 8, 2016, after Casino had executed a letter agreement memorializing its undertaking to launch the Offers (the "**Casino-Cnova Undertakings Letter**"), the Cnova Transaction Committee met by telephone, together with members of Cnova's management and representatives of BNP Paribas, Eight Advisory, Freshfields, Darrois, Lefosse, NautaDutilh, Trindade and Wachtell Lipton, to discuss and review the negotiated terms of the proposed reorganization transaction. Mr. Brunel presented an overview of recent negotiations with the Via Varejo special committee. A representative of Wachtell Lipton reviewed the terms of the draft Reorganization Agreement that had been negotiated with the Via Varejo special committee and its counsel, including the indemnification terms, the terms of the escrow arrangements and the mechanics of the working capital and financial net debt adjustment. A representative of Lefosse described certain of the termination provisions contained in the draft Reorganization Agreement. A representative of BNP Paribas made a presentation concerning its revised valuation of Cnova, Cnova Brazil and Cdiscount. Following the presentation by BNP Paribas, a representative of Eight Advisory made a financial presentation concerning the proposed reorganization and delivered its independent expert report on the financial terms of the proposed reorganization, including its opinion that, as of August 8, 2016 and based upon, and subject to, the factors and assumptions set forth therein, the consideration to be received by Cnova pursuant to the Reorganization Agreement (as it is defined below) was fair, from a financial point of view, to Cnova minority shareholders. A representative of Freshfields then reviewed with the directors the legal standards applicable to their decisions and actions with respect to the proposed reorganization. Following discussions and deliberations, including a determination that the Cnova Transaction Committee had made a thorough assessment of the Reorganization as compared to other strategic alternatives and having thoroughly considered the merits, advantages and potential disadvantages of the Transactions, and considering the interests of Cnova and its stakeholders, including Cnova's minority shareholders, the Cnova Transaction Committee, representing the Cnova board of directors, unanimously (i) determined that the Transactions are in the best interests of Cnova, its shareholders and all other stakeholders, (ii) determined that the Transactions are fair, advisable and in the best interests of unaffiliated Cnova shareholders, (iii) resolved to enter into the Transactions and (iv) resolved to recommend that the holders of Shares approve the Reorganization and directed that the Reorganization be submitted to Cnova's general meeting of shareholders for its approval.

*Translation for information purposes only.
In case of discrepancy between the French and the English version, the French version shall prevail.*

The Offer and this draft information memorandum in response remain subject to the review of the AMF

Following the meeting of the Cnova Transaction Committee, (i) Cnova, Cnova Brazil and Via Varejo executed the Reorganization Agreement, (ii) Cnova released its signature to the Casino-Cnova Undertakings Letter, (iii) Casino and CBD executed the Casino-CBD Commitment Letter (as defined in section 1.3 of the Offeror's offer memorandum) and (iv) CBD executed the CBD Support Letter, the terms of which are more fully described in section 1.3 of the Offeror's draft offer memorandum.

Following the close of trading on the NASDAQ of August 8, 2016, Casino, Cnova, Via Varejo and CBD issued press releases announcing the execution of the Reorganization Agreement and the Reorganization and Casino's agreement, subject to the completion of the Reorganization, to undertake the Offers.

On August 11, 2016, Via Varejo published the notice of an extraordinary general meeting of the Via Varejo shareholders, at which Via Varejo's shareholders would be asked to approve, among other matters, the Reorganization. On the same date, Via Varejo also published the proposal of Via Varejo's management with respect to the Reorganization for consideration at the extraordinary general meeting of the Via Varejo shareholders.

On September 12, 2016, Via Varejo's shareholders (other than CBD) voted to approve the Reorganization at Via Varejo's extraordinary general meeting of shareholders, with approximately 93.6% of the Via Varejo shareholders in attendance, in person or by proxy, voting in favor of the Reorganization.

Also on September 12, Cnova convened an extraordinary general meeting of shareholders to approve the Reorganization and take certain resolutions in connection with the Transactions.

On October 27, 2016, the extraordinary general meeting of shareholders, with 96.01% of shareholders present or having given proxy, approved the Reorganization with 99.99% of shareholders present or represented voting in favour of the Reorganization. The Reorganization was completed on October 31, 2016.

On December 1, 2016, the Cnova Transaction Committee had a meeting during which it analyzed the fairness opinion of Eight Advisory and decided to recommend the Cnova shareholders who are not affiliated with the Casino Group tender their Shares into the Offers.

*Translation for information purposes only.
In case of discrepancy between the French and the English version, the French version shall prevail.*

The Offer and this draft information memorandum in response remain subject to the review of the AMF

1.1.2. Context of the Offer

The steps involved in the completion of the Reorganization are described below, in a non-exhaustive manner.

The organizational structure of Cnova before the Reorganization was the following:

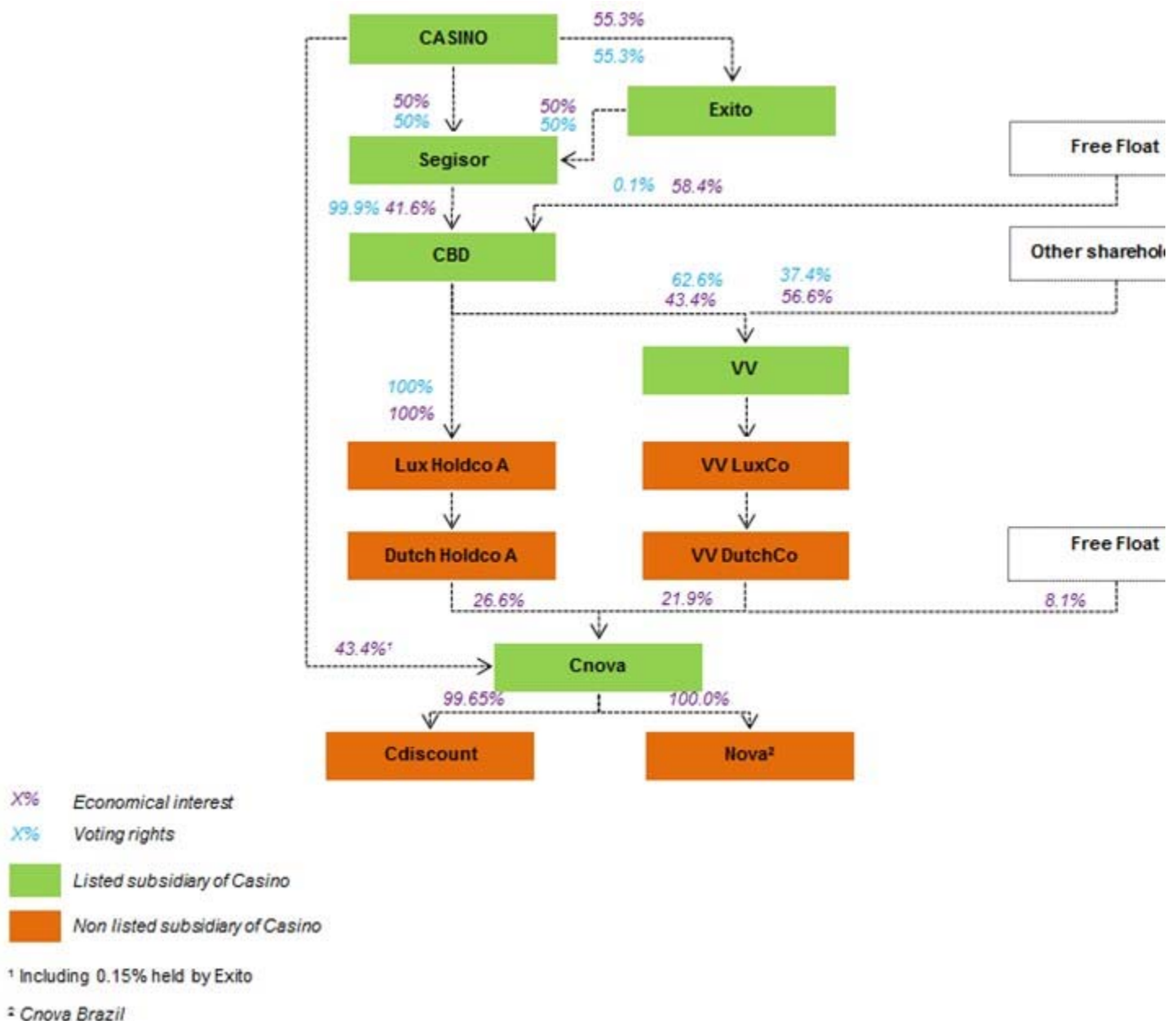

By way of introduction, the general scheme of the Reorganization may be summarized as follows.

- Cnova has granted Via Varejo (indirectly) part of the shares forming Cnova Brazil’s share capital through a distribution of these shares for the sole benefit of Via Varejo. This distribution was made possible by the prior conversion of all the 96,790,798 Shares indirectly held by Via Varejo into preferred shares (the “**Distribution Preferred Shares**”) which immediately entitled their sole holder to the allocation of a number of shares of Cnova Brazil equal in value to the common shares converted. After this distribution, the Distribution Preferred Shares, having no longer any value, were transferred (indirectly) free of charge by Via Varejo to Cnova for cancellation.

- The remaining shares of Cnova Brazil not distributed to Via Varejo (indirectly) was acquired by Cnova Brazil for a cash payment (the “**Balancing Payment**”), which was provisionally adjusted regarding financial net debts and working capital requirement of Cnova Brazil on the date of completion of the Reorganization (the “**Balancing Payment Adjustment**”) and may be adjusted on the basis of the final accounts. The Balancing Payment thus adjusted represents the difference in value between Cnova Bresil and the Via Varejo’s 21.9% interest in Cnova, valued at U.S. \$ 5.00 per Share. These cash amounts are financed by the sums transferred to Cnova Brazil by Via Varejo through a merger that occurred at the beginning of the Reorganization transactions between Cnova Brazil and a subsidiary of Via Varejo, VV Part, the assets of which were composed of cash and securities of companies holding the interest of Via Varejo in Cnova.

*Translation for information purposes only.
In case of discrepancy between the French and the English version, the French version shall prevail.*

The Offer and this draft information memorandum in response remain subject to the review of the AMF

Thus, at the completion of the Reorganization, Via Varejo holds the entire capital of Cnova Brazil and no longer holds any stake in Cnova. In the Reorganization, Cnova received:

- The Distribution Preferred Shares, which represented approximately 21.9% of the share capital of Cnova prior to their conversion and which will be canceled on or about January 4, 2017; and
- The Balancing Payment and Adjustment of the provisional compensatory payment for a total amount of R\$ 20,370,301 (i.e. an amount of EUR 5,855,217 at a 3.479 EUR / R\$ rate, without deduction of the taxes remaining to be paid by Cnova), which will be subject to a post-closing adjustment.

In addition, Cnova Brazil has repaid on November 8, 2016 the outstanding loan obligations which it owed to Cnova and Cnova Finança, together with all interest and any other accrued amounts up to the payment date (such principal amount, interest and other accrued amounts are referred herein as to the “**Repayment Amount**”). As of November 8, 2016, the aggregate principal amount and accrued interest owed under such loan agreements was R\$ 526.95 million. As a result of the Reorganization, Via Varejo became the sole shareholder of Cnova Brazil and is no longer a direct or indirect shareholder of Cnova, meaning an amount repay of EUR 145.99 million.

These operations are more detailed below.

(i) ***First step***

Via Varejo has contributed to a non-operating holding company, wholly-owned by it, VV Part Participações S.A (hereinafter referred to as “**VV Part**”), in counterpart of the issuance of new shares:

- all of the issued and outstanding shares of Via Varejo Holding S.à.r.l., a wholly-owned subsidiary of Via Varejo organized under the laws of Luxembourg (“**VV LuxCo**”). VV LuxCo holds indirectly through Via Varejo Holding Netherlands B.V., a wholly owned subsidiary of VV LuxCo, organized under the laws of the Netherlands (“**VV DutchCo**”); 96,790,798 Shares, representing the overall holding in Via Varejo in Cnova (i.e. 21.9% of the Shares).
- A cash supplement enabling VV Part to have sufficient equity to (i) enable Cnova Brazil to subsequently pay the Compensatory Payment and the Balancing Payment Adjustment and (ii) to make the subsequent merger between VV Part and Cnova Brazil possible in accounting terms.

*Translation for information purposes only.
In case of discrepancy between the French and the English version, the French version shall prevail.*

The Offer and this draft information memorandum in response remain subject to the review of the AMF

Cnova Brazil has then absorbed VV Part by way of merger (hereinafter referred to as the “**VV Part merger**”). Following the merger of VV Part, Cnova Brazil held 100% of the share capital of VV LuxCo and Cnova held a 44.8% stake in Cnova Brazil, the balance being held by Via Varejo.

The following diagram represents the organigram of Cnova at the end of this first step:

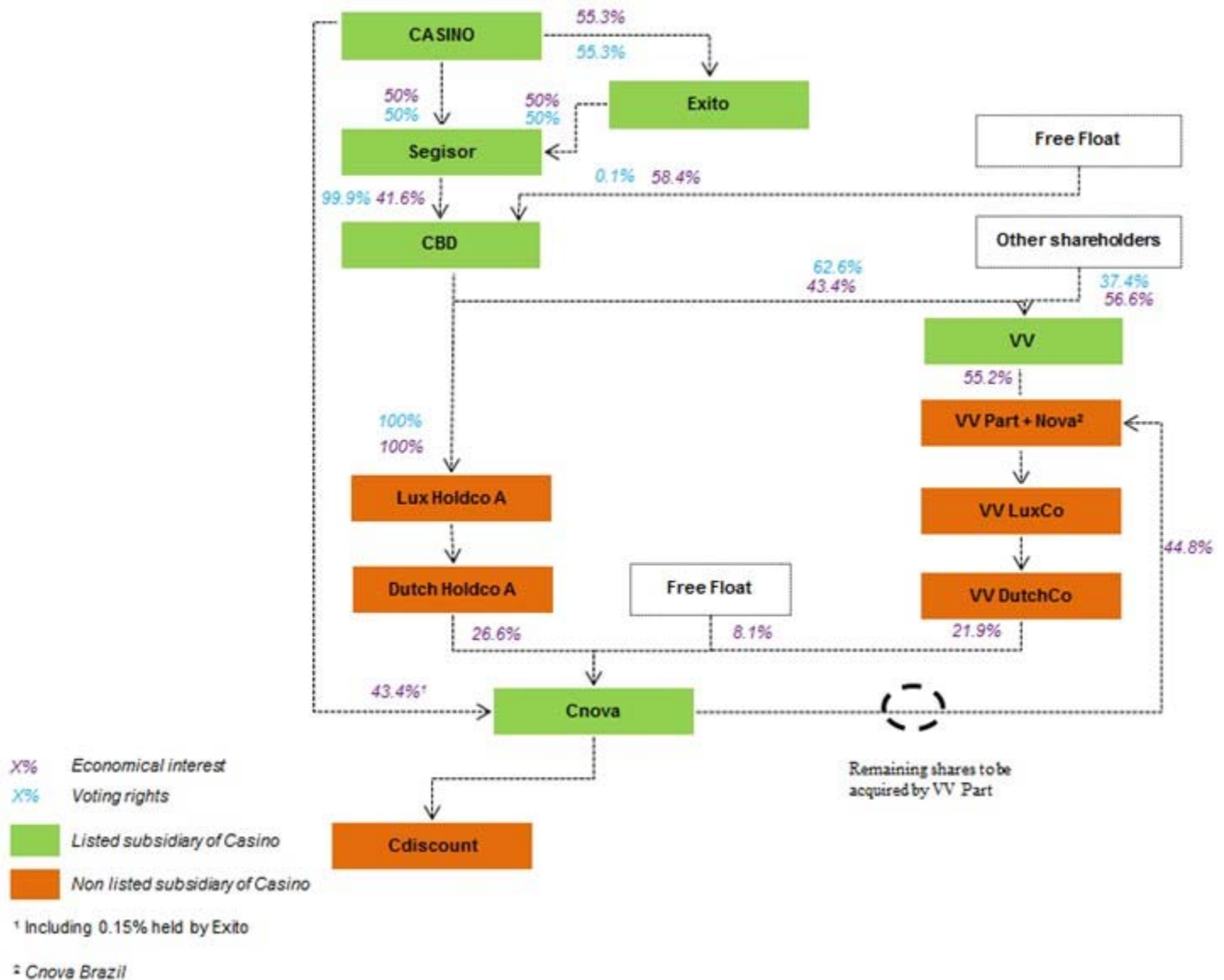

(ii) **Second step**

Cnova has converted its own 96,790,798 Shares (corresponding to 21.9% of its share capital) held by VV DutchCo into special shares which confer the right to an exceptional distribution in kind of Cnova Brazil shares (the “**Distribution Preferred Shares**”).

Cnova, has made under the Distribution Preferred Shares, a distribution in kind of 73,974,479 Cnova Brazil shares (out of a total of 74,924,847 shares it held) to VV DutchCo for an amount equal to the actual value of the Shares that have been converted to Distribution Preferred Shares, contractually valued between Cnova and Via Varejo at U.S. \$ 5.00 per share. The Cnova Brazil distributed shares were successively distributed up to Cnova Brazil and have been canceled

Immediately after this distribution, Cnova acquired all the Distribution Preferred Shares free of charges held by VV

DutchCo, for the purpose of cancellation.

*Translation for information purposes only.
In case of discrepancy between the French and the English version, the French version shall prevail.*

The Offer and this draft information memorandum in response remain subject to the review of the AMF

The following diagram represents the organigram of Cnova at the end of this second step:

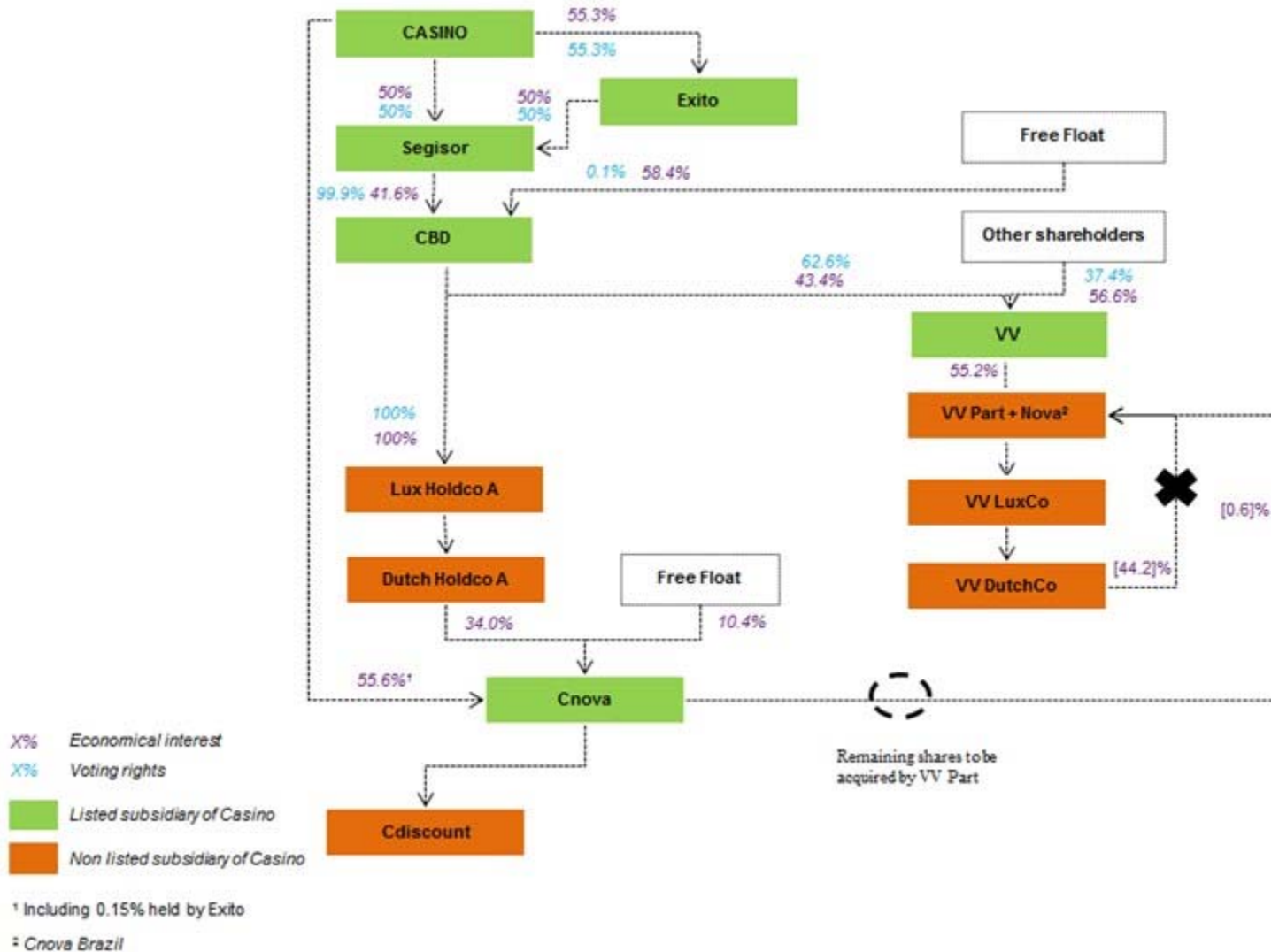

(iii) **Third step**

Immediately thereafter, Cnova sold the remaining Cnova Brazil shares held by it (i.e. 950,368 shares for an aggregate cash payment of approximately R\$ 20.4 million (i.e., approximately € 5.9 million, at a 3.48 EUR/R\$ rate, subject to post-closing adjustments, and without deduction of the taxes remaining to be paid by Cnova) representing the Balancing Payment and the Balancing Payment Adjustment.

Upon completion of the Reorganization, Cnova Brazil has been wholly-owned by Via Varejo (and is expected to be subsequently merged into Via Varejo). In addition, Via Varejo no longer has any direct or indirect interest in Cnova and Cnova no longer has any interest in Cnova Brazil.

*Translation for information purposes only.
In case of discrepancy between the French and the English version, the French version shall prevail.*

The Offer and this draft information memorandum in response remain subject to the review of the AMF

The following diagram represents the actual Cnova organigram:

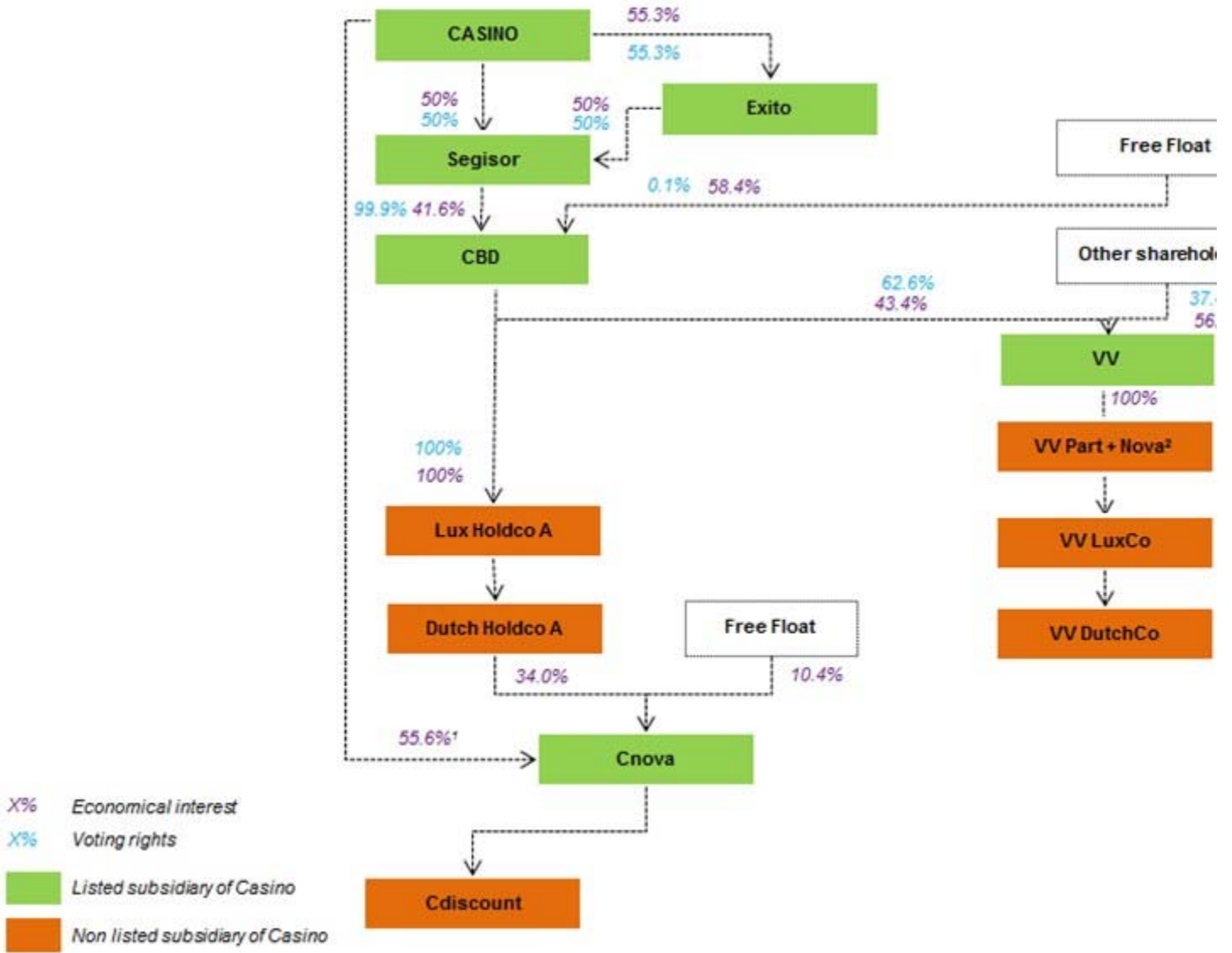

¹ Including 0.15% held by Exito

² Cnova Brazil

*Translation for information purposes only.
In case of discrepancy between the French and the English version, the French version shall prevail.*

The Offer and this draft information memorandum in response remain subject to the review of the AMF

1.1.3. Transaction agreements

The following describes the principal terms of the agreements that have been entered into in the context of the Transactions, in a non-exhaustive manner.

(i) ***The Reorganization Agreement***

As mentioned in section 1.2 of the Offeror's draft information memorandum, the Reorganization was completed on October 31, 2016.

The economic basis of the Reorganization Agreement is described in section 1.2 of the Offeror's draft information memorandum.

Balancing Payment Adjustment

Under the Reorganization Agreement, the Balancing Payment was subject to adjustment based on the level of financial net debt and working capital requirements of Cnova Brazil at the closing (the Balancing Payment Adjustment). If the (negative) amount of working capital requirements minus the amount of financial net debt of Cnova Brazil at closing exceeded a specified target amount (which is referred to herein as the "**Target Amount**") by more than 5%, the Balancing Payment was to be adjusted upward by the amount of such excess. Conversely, if the amount of working capital requirements minus the amount of financial net debt of Cnova Brazil at closing was less than the Target Amount by more than 5%, the balancing payment was to be adjusted downward by the amount of such deficit. The target amount depended on the date of the closing, and was based on end-of-month negotiated target levels of Cnova Brazil's working capital requirements and financial net debt. The global Balancing Payment Adjustment on October 31, 2016 was of R\$ 3.9 million (on a preliminary basis and subject to the final financial statements).

This amount may be subject to a post-closing adjustment in accordance with the terms of the Reorganization Agreement.

*Translation for information purposes only.
In case of discrepancy between the French and the English version, the French version shall prevail.*

The Offer and this draft information memorandum in response remain subject to the review of the AMF

Representations and Warranties

The Reorganization Agreement contains customary representations and warranties of Via Varejo, Cnova and Cnova Brazil that are subject, to specified exceptions and qualifications.

Each of Cnova, Cnova Brazil and Via Varejo made representations and warranties with respect to, among other things:

- organization, good standing and qualification to do business;
- corporate authority and approval relating to the execution, delivery and performance of the Reorganization Agreement;
- the absence of any need for action by governmental authorities in order to complete the mergers, other than actions set forth in the Reorganization Agreement;
- enforceability of the Reorganization Agreement and all other documents necessary to implement the Reorganization;
- absence of proceedings concerning insolvency or bankruptcy; and
- the absence of any conflict with or violation or breach of organizational documents or any conflict with or violation of agreements, laws or regulations as a result of the execution, delivery and performance of the Reorganization Agreement and implementation of the Reorganization.

The Reorganization Agreement also contains additional representations and warranties of Cnova that relate to, among other things:

- ownership of and title to Cnova Brazil shares;
- the organization, good standing and qualification to do business of Cnova Brazil and its subsidiaries;
- licenses, records, registrations, permits and consents related to Cnova Brazil's business;
- unaudited financial statements of Cnova Brazil as of June 30, 2016;
- compliance with applicable laws and ongoing litigation;
- conduct of business in the ordinary course by Cnova Brazil between June 30, 2016 and the date of the Reorganization Agreement;
- subsidiaries of Cnova Brazil;
- branches and establishments of Cnova Brazil;
- real estate and other property owned by Cnova Brazil;
- absence of undisclosed liabilities;
- certain contracts of Cnova Brazil and its subsidiaries;
- labor and employment matters at Cnova Brazil;
- employee benefit plans;
- corporate taxes;
- insurance policies at Cnova Brazil;
- guarantees and similar obligations of Cnova Brazil;
- powers of attorney granted by Cnova Brazil and its subsidiaries;

- certain Cnova Brazil intellectual property; and
- certain environmental matters.

*Translation for information purposes only.
In case of discrepancy between the French and the English version, the French version shall prevail.*

The Offer and this draft information memorandum in response remain subject to the review of the AMF

Other disposition

Implementation of the Reorganization Steps. Each of Cnova, Cnova Brazil and Via Varejo agreed to carry out, or cause to be carried out, the reorganization steps at the times and on the conditions set forth in the Reorganization Agreement. Cnova has undertaken that Cnova Brazil will not take certain significant decisions until the Reorganization has been completed without the consent of Via Varejo.

Regulatory Approvals. Each of Cnova, Cnova Brazil and Via Varejo agreed to cooperate and proceed with actions required to do whatever was or would have reasonably been expected to be necessary or advisable to obtain any regulatory authorization to implement the Reorganization.

Via Varejo and Cnova Shareholder Meetings. Each of Cnova and Via Varejo agreed to, as soon as reasonably practicable after the date of the Reorganization Agreement: (i) take all actions necessary to duly call and hold a meeting of its respective shareholders for the purpose of adopting the Reorganization Agreement, (ii) include in any shareholders circular required to be prepared a recommendation of the board of directors that its shareholders approve the Reorganization Agreement and (iii) use its reasonable best efforts to obtain necessary shareholder approvals. Each of Via Varejo's and Cnova's shareholders' meeting were held on September 12, 2016 and October 27, 2016, respectively.

Schedule 13E-3. Among other things, Via Varejo and Cnova agreed to cooperate, and to cause their respective financial advisors to cooperate, in the preparation of a Transaction Statement on Schedule 13E-3, a required disclosure document under U.S. Regulations. Each of Via Varejo and Cnova further agreed to furnish, and to cause their respective financial advisors to furnish, all applicable information concerning Via Varejo or Cnova, as applicable, and their respective subsidiaries, officers, directors, stockholders and affiliates, and to take any other actions, as may be reasonably requested in connection with the foregoing. The Schedule 13E-3 was first filed with the SEC on August 23, 2016 and the most recently amended, as of the date of this Memorandum, on last filing was made on November 1, 2016. The Schedule 13E-3 is available on the website of the U.S. Securities and Exchange Commission (www.sec.gov).

Transfer of Operations and Personnel. Each of the parties to the Reorganization Agreement agreed to cooperate and do whatever was or would have reasonably been expected to be necessary to implement (i) the transfer of the assets and liabilities of Cnova Brazil to Via Varejo and (ii) the transfer of personnel from Cnova Brazil to Via Varejo. Via Varejo has agreed with the treatment of the long term incentive plan benefitting the personnel of Cnova Brazil determined by Cnova's board of directors. Upon completion of the Reorganization, Via Varejo (i) issued to such employees of Cnova Brazil securities replacing the deferred stock units and (ii) entered into amendments to the "cash long term investment plans", in each case as specified in the Reorganization Agreement.

Cnova Finança Restructuring. Prior to the Reorganization Date, Cnova agreed to cause Cnova Brazil to sell and transfer to Cnova all shares of Cnova Finança held by Cnova Brazil so that following the completion of such sale and transfer, Cnova Brazil will no longer have any interest in Cnova Finança. The shares of Cnova Finança held by Cnova Brazil were transferred to Cnova on October 17, 2016.

*Translation for information purposes only.
In case of discrepancy between the French and the English version, the French version shall prevail.*

The Offer and this draft information memorandum in response remain subject to the review of the AMF

Indemnification

Indemnification by Cnova. Subject to certain limitations, Cnova agreed to indemnify and hold harmless Via Varejo, its affiliates, Cnova Brazil and any of their respective successors and assigns, (the “**Via Varejo Indemnified Parties**”), from and against any and all losses, damages, penalties, liabilities, costs, charges and expenses, which is referred to herein as “**Losses**”, that may be incurred by Via Varejo Indemnified Parties directly or indirectly resulting from:

- any breach or inaccuracy of any representation or warranty made by Cnova;
- any breach of any covenant or any other obligation of Cnova and, prior to October 31, 2016, Cnova Brazil under the Reorganization Agreement;
- the actions, suits, investigations or any proceedings by third persons arising in connection with or related to the accounting practices and employee misconduct relating thereto of Cnova Brazil that were identified by the investigation described in Item 15 of Cnova’s Annual Report on Form 20-F filed with the SEC on July 22, 2016, (the “**Cnova Brazil Accounting Investigation**”), provided that Cnova will not be required to indemnify the Via Varejo Indemnified Parties if, and only to the extent that, such Loss is determined by a governmental entity to arise out of or result from a Via Varejo Indemnified Party’s former status as a Cnova shareholder;
- the consolidated federal securities lawsuit styled In re Cnova N.V. Securities Litigation, No. 16-cv-444 (LTS) (S.D.N.Y. filed Jan. 20, 2016), as it may be amended from time to time, (the “**Cnova Shareholder Lawsuit**”), provided that Cnova will not be required to indemnify the Via Varejo Indemnified Parties if, and only to the extent that, such Losses are determined by a governmental entity to arise out of or result from a Via Varejo Indemnified Party’s former status as a Cnova shareholder;
- the Cnova Finança restructuring or any claim arising from facts, acts, events or omissions related to Cnova Finança or the ownership by Cnova Brazil of Cnova Finança, in each case at any time prior to the Reorganization Date;
- the actions, suits or proceedings against Cnova Brazil or any of its subsidiaries (other than Cnova Finança) relating to any claim by any customer of Cnova Brazil or any of its Subsidiaries (other than Cnova Finança) in connection with products sold by Cnova Brazil or any of its subsidiaries (other than Cnova Finança) prior to October 31, 2016, (collectively, the “**Cnova Brazil Consumer Claims**”);
- the actions, suits or proceedings against Cnova Brazil or any of its subsidiaries (other than Cnova Finança) relating to labor, employee or employment claims with respect to any conduct that occurred prior to October 31, 2016, but excluding any such action, suit or proceeding brought by or on behalf of any employee of Cnova Brazil or any of its subsidiaries (other than Cnova Finança) who is terminated by Via Varejo or any of its subsidiaries (including, from and after the Reorganization Date, Cnova Brazil and its subsidiaries (other than Cnova Finança)) upon or following the closing, (collectively, the “**Cnova Brazil Labor Claims**”); and
- Specified tax matters.

*Translation for information purposes only.
In case of discrepancy between the French and the English version, the French version shall prevail.*

The Offer and this draft information memorandum in response remain subject to the review of the AMF

Limitations on Indemnification. Cnova's indemnification obligations are subject to the following limitations:

- *General Deductible:* The Via Varejo Indemnified Parties are not entitled to indemnification for breaches of representations and warranties (other than certain “**Fundamental Representations**”) or for tax matters unless (and then only to the extent) the aggregate amount of all Losses arising from such claims exceeds approximately R\$25.3 million^[3] and only for the surplus;
- *Consumer Claims Deductible.* The Via Varejo Indemnified Parties are not entitled to indemnification for Cnova Brazil Consumer Claims unless (and then only to the extent) the aggregate amount of all losses arising from such claims exceeds approximately R\$20.5 million^[4] and only for the surplus;
- *Labor Claims Deductible.* The Via Varejo Indemnified Parties are not entitled to indemnification for Cnova Brazil Labor Claims unless (and then only to the extent) the aggregate amount of all losses arising from such claims exceeds approximately R\$22,300^[5] and only for the surplus;
- *Cap.* Cnova's indemnification obligations are capped at approximately R\$189.9 million^[6], except with respect to the following matters:

³ Or approximately € 7.11 million on the basis of an exchange rate of BRL 3.554 per 1 euro on 22 November 2016

⁴ Or approximately € 5.77 million on the basis of an exchange rate of BRL 3.554 per 1 euro on 22 November 2016

⁵ Or approximately € 6.27 million on the basis of an exchange rate of BRL 3.554 per 1 euro on 22 November 2016

⁶ Or approximately € 6,275 on the basis of an exchange rate of BRL 3.554 per 1 euro on 22 November 2016

*Translation for information purposes only.
In case of discrepancy between the French and the English version, the French version shall prevail.*

The Offer and this draft information memorandum in response remain subject to the review of the AMF

- Losses arising from breaches of Fundamental Representations and covenants;
 - Losses arising from taxes indemnifiable in connection with the Cnova Brazil Accounting Investigation;
 - Losses relating to the Cnova Shareholder Lawsuit; and
 - Losses arising from the Cnova Finança restructuring.
- *De Minimis Threshold.* Via Varejo is not entitled to indemnification for breach of a representation or warranty unless the resulting Losses exceeds approximately R\$158,300^[7] (or approximately R\$15,800^[8], in the case of a specified fundamental representation).

Indemnification by Via Varejo. Subject to certain limitations, Via Varejo agreed to indemnify and hold harmless Cnova and its affiliates (other than Via Varejo and its subsidiaries, including Cnova Brazil from and after the Reorganization Date) and any of their respective successors and assigned from and against any and all Losses directly or indirectly resulting from:

- any breach or inaccuracy of any representation or warranty made by Via Varejo; and
- any breach of any obligation of Via Varejo and, from and after the Reorganization Date, Cnova Brazil under the Reorganization Agreement.

Escrow Fund and Optional Guarantees

Escrow Agreement. Promptly following the date of the Reorganization Agreement, Cnova and Via Varejo agreed to negotiate in good faith to agree on the terms of an Escrow Agreement (the “**Escrow Agreement**”), and to enter into the Escrow Agreement prior to the Reorganization Date. The Escrow Agreement was signed on October 31, 2016.

Release of Escrow Funds. The parties agreed to release the amounts contained in the escrow fund from the initial US\$60 million as follows:

- *First anniversary of the Reorganization Date.* On October 31, 2017 all funds, if any, then-remaining in the escrow account in excess of the sum of (i) U.S. \$50.0 million plus (ii) any amounts on account of noticed and pending claims existing as of such date will be released to Cnova. The amounts of any noticed and pending claims referred to in the prior sentence shall be paid to Via Varejo as and when required in accordance with the Reorganization Agreement and Escrow Agreement and after the resolution and payment of any of such claims, any funds remaining in the escrow account in excess of U.S. \$ 50.0 million that were previously not released on account of such claim will be released to Cnova.

⁷ Or approximately € 5,445.38.11 million on the basis of an exchange rate of BRL 3.554 per 1 euro on 22 November 2016

⁸ Or approximately € 4.445,38 million on the basis of an exchange rate of BRL 3.554 per 1 euro on 22 November 2016

*Translation for information purposes only.
In case of discrepancy between the French and the English version, the French version shall prevail.*

The Offer and this draft information memorandum in response remain subject to the review of the AMF

- *Second anniversary of the Reorganization Date.* On October 31, 2018 all funds, if any, then-remaining in the escrow account in excess of the sum of (i) U.S. \$40.0 million plus (ii) any amounts on account of noticed and pending claims existing as of such date will be released to Cnova. The amounts of any noticed and pending claims referred to in the prior sentence shall be paid to Via Varejo as and when required in accordance with the Reorganization Agreement and Escrow Agreement and after the resolution and payment of any of such claims, any funds remaining in the escrow account in excess of U.S.\$ 40.0 million that were previously not released on account of such claim will be released to Cnova.
- *Sixth anniversary of the Reorganization Date.* On October 31, 2022 all funds, if any, remaining in the escrow account less the aggregate of amount of noticed and pending claims existing as of such date will be released to Cnova. After the resolution and payment of such noticed and pending claims, all funds remaining in the escrow account will be released to Cnova.

Substitution of Guarantee. At any time before October 31, 2022, if Cnova provides a guarantee or letter of credit from a bank or similar financial institution in a mutually agreeable form or a guarantee from Casino in form and substance reasonably acceptable to Via Varejo in an amount equal to the then-remaining funds in the escrow account, the amount of funds, if any, then-remaining in the escrow account will be released to Cnova. Until October 31, 2022, the maximum liability at any time pursuant to such bank guarantee or Casino guarantee will be capped at the amount that would have otherwise been in the escrow account at such time and at the sixth anniversary of the Reorganization Date Cnova and Via Varejo have agreed to take all steps necessary to cause any such guarantee to be of no continuing force or effect.

Good Faith Reevaluation. At the third anniversary of the Reorganization Date, the parties have agreed to discuss in good faith whether, as a result of Cnova's then-current financial position as compared to the expected financial position of Cnova as of immediately following October 31, 2016, the indemnification obligations of Cnova would reasonably be expected to present an unacceptable risk of non-payment, taking into account such matters that the respective boards of directors of Via Varejo and Cnova deem relevant and appropriate. Following such discussions, the parties may agree to release additional funds from escrow or alter the terms of any guarantee then in place.

Governing Law; Dispute Resolution; Specific Performance

Governing Law. The Reorganization Agreement is governed and construed pursuant to the laws of the Federative Republic of Brazil.

Dispute Resolution. Cnova and Via Varejo have agreed to use best efforts to settle any disputes related to the agreement by private negotiation during the 15 days following either party giving notice of a dispute. If resolution is not reached within 15 days, the parties agreed to submit all disputes to confidential and binding arbitration in front of a three arbitrator panel. Each party is entitled to appoint one arbitrator and the party-nominated arbitrators will jointly appoint the third arbitrator. The parties are permitted to seek judicial assistance for the limited purposes of (i) compelling arbitration; (ii) obtaining interim measures of protection rights during the pendency of the arbitral proceedings; and (iii) enforcing any decision of the arbitrators including the final award. The parties agreed that the Courts of the City of São Paulo, Brazil, will have jurisdiction for such purposes.

*Translation for information purposes only.
In case of discrepancy between the French and the English version, the French version shall prevail.*

The Offer and this draft information memorandum in response remain subject to the review of the AMF

Specific Performance. Cnova, Cnova Brazil and Via Varejo have agreed that each is entitled to seek specific performance of the Reorganization Agreement in accordance with the Brazilian Code of Civil Procedure, without prejudice to reimbursement for losses and damages incurred by the enforcing party as a result of the other party's failure to perform.

(ii) New Operational Agreement

In connection with the execution of the Reorganization Agreement, CBD and Via Varejo entered into a new operational agreement, that became effective upon completion of the Reorganization, establishing the terms and conditions for the commercial and strategic alignment of their retail and eCommerce activities, in particular with respect to joint acquisitions of common products and eCommerce activities under the brand "**Extra**". Also upon completion of the Reorganization, the existing operational agreement among CBD, Via Varejo, Cnova Brazil and Cnova will be terminated. The existing operational agreement among CBD, Via Varejo, Cnova Brazil and Cnova is described under Item 7.B. of Cnova's Annual Report on Form 20-F for the year ended December 31, 2015, filed with the SEC on July 22, 2016.

(iii) The Casino-Cnova Undertakings Letter

In connection with the Reorganization, Casino and the Cnova Transaction Committee entered into the Casino-Cnova Undertakings Letter, pursuant to which Casino agreed to launch the Offers promptly following the completion of the Reorganization. The following describes the material provisions of the Casino-Cnova Undertakings Letter. The summary does not purport to be complete and may not contain all of the information about the Casino-Cnova Undertakings Letter that may be important to Cnova shareholders.

Casino Undertakings. Pursuant to the Casino-Cnova Undertakings Letter, subject to (i) the completion of the Reorganization and (ii) the Cnova board of directors and/or Transaction Committee supporting the Offers and rendering, on or prior to the execution of the Reorganization Agreement, a positive opinion and position statement with respect to the Offers, and immediately prior to the filing of the French Offer with the AMF, confirming their positive reasoned opinion in view of an independent expert's fairness opinion, Casino has agreed to do the following, among other things:

- *Offers commitment.* Launch the Offers promptly upon completion of the Reorganization for any and all Shares at a price of U.S. \$5.50 (with respect to the U.S. Offer) and an equivalent amount in euros with respect to the French Offer;
- *Support of the Combination.* Vote in favor of the Reorganization at Cnova's extraordinary general meeting of shareholders, in its capacity as a Cnova shareholder; and
- *Stock Appreciation Rights.* Authorize, in accordance with the terms of the Stock Appreciation Rights (SAR) granted in November 2014 by Casino to certain employees of Cnova who will be transferred to Via Varejo on the basis of the Reorganization, the adjustment of the terms of said SAR proposed by the Cnova Transaction Committee as described in paragraph 2.2.4 of the Offeror's draft information memorandum.

Casino has no right to terminate its undertakings unless if Cnova issues or resolves or commits to issue additional Shares, prior to launch of the Offers.

*Translation for information purposes only.
In case of discrepancy between the French and the English version, the French version shall prevail.*

The Offer and this draft information memorandum in response remain subject to the review of the AMF

(iv) The Casino and CBD Letters

In connection with the Reorganization, Casino and CBD made certain undertakings to each other pursuant to a letter agreement from CBD to Casino, dated August 8, 2016, (the “**CBD Support Letter**”), and a letter agreement addressed to the CBD independent committee and executed by Casino and CBD, dated August 8, 2016, (the “**Casino-CBD Commitment Letter**”). The CBD Support Letter and the Casino-CBD Commitment Letter are intended to govern the parties’ ongoing relationship to each other in their capacity as shareholders of Cnova following completion of the Reorganization and the Offers.

The following describes the material provisions of the Casino-CBD Commitment Letter and the CBD Support Letter. The summary does not purport to be complete and may not contain all of the information about the CBD Support Letter and Casino-CBD Commitment Letter that may be important to Cnova shareholders.

CBD Support Letter

Pursuant to the CBD Support Letter, signed on August 8, 2016, CBD informed Casino that at the meeting held on August 8, 2016 the CBD board of directors unanimously resolved (i) to cause its voting rights to be exercised at any Cnova shareholders meeting in favor of the Reorganization, (ii) not to tender the 177,303,664 Shares it indirectly holds (the “**Subject Shares**”) directly or indirectly into the Offers, nor otherwise dispose of or transfer the Subject Shares in any other manner or through any other instrument, including any derivative instruments until completion of the Offers. CBD further agreed to stand alongside and cooperate with Casino in subsequent Squeeze-Out proceedings, if any, following completion of the Offers.

Casino-CBD Commitment Letter

CBD Undertakings. In the event that CBD decides to sell any of the Subject Shares to a third party, CBD undertakes to (i) first offer the Subject Shares to Casino at the price offered by the third party and (ii) if Casino do not wish to buy the Subject Shares or if Casino and CBD do not reach an agreement on the purchase price of the Subject Shares, to impose on the proposed buyer to acquire up to the same proportion of Shares held by Casino, more or less simultaneously and under the same conditions.

Casino Undertakings. In consideration for CBD undertaking not to tender its Shares to Cnova to the Offers, Casino has taken the following undertakings which became enforceable upon completion of the Reorganization

- ***Director Designation Rights.*** Casino will ensure that CBD has the right to designate at least one member to the Cnova board of directors so that the ratio of (i) non-independent members of the Cnova board of directors appointed by CBD *divided by* (ii) the total number of non-independent directors is at least equal to CBD’s economic interest in Cnova’s outstanding Shares (such director or directors, the “**CBD Directors**”);
- ***Information Rights.*** Casino will ensure that CBD and/or the CBD Directors have access to the following information with respect to Cnova: (i) audited statutory and consolidated accounts, (ii) annual budget and forecast, (iii) half-year and quarterly accounts, (iv) annual report, (v) details of any material change in business, financial position or affairs and (vi) any other information that may be required for CBD to comply with Brazilian capital markets regulations. Casino also agreed to cause Cnova to make members of Cnova’s senior management reasonably available to CBD or the CBD Directors;

*Translation for information purposes only.
In case of discrepancy between the French and the English version, the French version shall prevail.*

The Offer and this draft information memorandum in response remain subject to the review of the AMF

- *Good Faith Consideration of an IPO.* If, as a result of the Offers, Shares are no longer listed on the NASDAQ or Euronext Paris, Casino has agreed to consider in good faith the opportunity to launch, in due time and depending on Cnova's then-current strategic and financial objectives and then-prevailing market conditions, an initial public offering of Cnova or, as the case may be, any subsidiary thereof, which is referred to herein as an "**IPO**";
- *Good Faith Consideration of a Fully Marketed Offering.* If, following the Offers, Shares continue to be listed on the NASDAQ or Euronext Paris, Casino agreed to consider in good faith the opportunity to launch a fully marketed offering, which is referred to herein as an "**FMO**", through the sale of a significant portion of Shares, aimed at increasing the free float and liquidity of Shares;
- *IPO or FMO Assessment Right.* CBD may require Casino to engage a first-tier advising bank selected by Casino to assess in good faith the opportunity of an IPO or an FMO and in both cases the opportunity and feasibility of a secondary placement (i.e., through the sale of existing Shares). CBD may not exercise such right only two years after the signing of the CBD – Casino Commitment Letter and then no more than once in any two year period;
- *IPO and FMO Priority.* If Casino or Cnova decides to initiate an IPO or FMO (including any secondary offering), CBD has the right to sell all of its shares as part of such offering, with priority over Casino with respect to up to 90% of the total shares to be offered in such secondary offering, subject to certain exceptions;
- *Tag Along Rights (Change-in-Control Transaction).* Casino has agreed that, if it intends to transfer any or all of its Shares to any third party (except for sales among members of the Casino Group or the controlling affiliates of Casino), which transfer will constitute a change-in-control of Cnova, CBD will be entitled to require the transferee to acquire all of its shares in Cnova at approximately the same time and on the same conditions;
- *Tag Along Rights (Not a Change-in-Control Transaction).* Casino agreed that if it intends to transfer any or all of its Shares to any third party (except for sales among members of the Casino Group or the controlling affiliates of Casino), which transfer will not constitute a change-in-control of Cnova, CBD will be entitled to require the transferee to acquire up to the same portion of the Subject Shares at approximately the same time and on the same conditions; and
- *Survival of Rights.* In the case of any reorganization or other corporate transaction involving Cnova resulting in an exchange, redemption or allotment of Shares (other than in a transaction where CBD would have the right to sell all of its Shares on the same conditions as Casino), Casino has agreed to ensure that CBD keeps the rights granted or receives rights similar to those granted by the Casino-CBD Commitment Letter with respect to the surviving entity.

The undertakings of Casino and CBD in the Casino-CBD Commitment Letter survive until the earliest of (i) the day when Casino no longer controls, directly or indirectly, Cnova, (ii) the day when CBD is no longer a shareholder of Cnova and (iii) August 8, 2041.

*Translation for information purposes only.
In case of discrepancy between the French and the English version, the French version shall prevail.*

The Offer and this draft information memorandum in response remain subject to the review of the AMF

II. Elements that could have an impact in case of a public Offer

2.1. Details of the company's capital

2.1.1. Double Voting Rights Structure

In connection with its initial public offering in November 2014, Cnova has implemented a special voting structure (the “**Double Voting Right Structure**”) that allowed a limited number of founding shareholders (including Casino, CBD, Via Varejo, Éxito and holding companies controlled by certain current and former managers of Cnova Brazil, collectively, the “**Founding Shareholders**”) to receive a second voting right for the Shares held by them at the time of the IPO so long as such Shares remaining registered in their name in a securities register maintained by Cnova (the “**Qualifying Shares**”). For this purpose, Stichting Cnova Special Voting Shares (the “**Voting Foundation**”), was been incorporated to serve as a voting depository. Cnova issued to the benefit of the Voting Foundation (without consideration) a number of special voting shares (each bearing a voting right but effectively no right to dividend) equal to the number of Qualifying Shares. Symmetrically, the Voting Foundation has issued special voting depository receipts (the “**Depository Receipts**”) to each Founding Shareholder in respect of the special voting shares held by the Voting Foundation. Thus, each Founding Shareholder received a number of Depository Receipts equal to the number of Qualifying Shares it held. The Depository Receipts entitle the relevant Founding Shareholders to obtain, before each meeting of Cnova shareholders, a voting proxy from the voting depository that permits the Founding Shareholders to vote the special voting shares represented by their Depository Receipts at such general meeting (in person or by proxy), or to instruct the Voting Foundation to vote such special voting shares at the meeting on behalf of the Founding Shareholder, in each case, pursuant to the relevant terms of the Double Voting Right Structure. Founding Shareholders who decide to sell all or part of their Qualifying Shares or to deregister them (in order to have them registered in a clearing system for instance) lose the Depository Receipts corresponding to such Qualifying Shares and the underlying special voting shares held by the Voting Foundation are transferred without consideration to Cnova. Only in limited cases, such as the transfer of Qualifying Shares by a Founding Shareholder to a transferee at least 90%-controlled by it, can the transferee receive Depository Receipts with respect to the transferred Qualifying Shares, subject to certain relevant terms of the Double Voting Right Structure. Further, shares acquired by Founding Shareholders do not entitle them to receive new Depository Receipts except in the case of shares subscribed as part of a capital increase—in which case Cnova would issue new special voting shares to the Voting Foundation. Except under the limited circumstances described above,, the Founding Shareholders cannot dispose of their Depository Receipts and the Voting Foundation cannot dispose of its special voting shares except when it transfers them to Cnova. There is special voting depository receipts in respect of special voting shares held by Cnova itself.

As a result of the Reorganization, the Depository Receipts held by Via Varejo were cancelled and the Voting Foundation transferred 96,790,798 special voting shares to Cnova for no consideration. At the Cnova EGM on October 27, 2016, Cnova shareholders resolved to cancel the 96,760,798 special voting shares. The cancellation should take effect on or around January 4, 2017.

As of the date of this draft offer memorandum, 314,940,097 special voting shares in the capital of Cnova are issued and outstanding, all being owned by the Voting Foundation, in respect of which the Voting Foundation has issued 314,940,097 special voting depository receipts to the persons shown below.

*Translation for information purposes only.
In case of discrepancy between the French and the English version, the French version shall prevail.*

The Offer and this draft information memorandum in response remain subject to the review of the AMF

2.1.2. Capital distribution

The following table presents, as of the date hereof, the capital and voting rights of the Company following the completion of the Reorganization.

Shareholders	Number of Shares	% of Share Capital	Number of Special Voting Depository Receipts	Number of Special Voting Shares	% of Voting Rights
Casino, Guichard-Perrachon	190 974 069	55,4340%	190 974 069	0	57,9194%
Almacenes Exito S.A. ^[9]	659 383	0,1914%	659 383	0	0,2000%
Companhia Brasileira de Distribuicao Netherlands Holding B.V. ^[10]	117 303 664	34,0497%	117 303 664	0	35,5764%
<i>SUB- TOTAL CASINO GROUP</i>	<i>308 937 116</i>	<i>89,6751%</i>	<i>308 937 116</i>		<i>93,6958%</i>
Euris S.A. ^[11]	2 500 000	0,7257%	0	0	0,3791%
Board members	147 767 ^[12]	0,0004%	0	0	0,0224%
Other holders of bearer shares	26 535 127	7,7023%	0	0	4,0224%
<i>SUB-TOTAL FREE FLOAT</i>	<i>29 182 894</i>	<i>8,4709%</i>	<i>0</i>	<i>0</i>	<i>4,4254%</i>
QE Participações Ltda.	6 002 981	1,7425%	6 002 981	0	1,8206%
Other registered shareholders	384 057	0,1115%	0	0	0,0582%
<i>SUB-TOTAL REGISTERED SHAREHOLDERS</i>	<i>6 387 038</i>	<i>1,8540%</i>	<i>6 002 981</i>		<i>1,8788%</i>
Stichting Cnova Special Voting Shares	0	0%	0	314 940 097	0%
TOTAL	344 507 048	100%	314 940 097	314 940 097	100%
<i>For information purposes : Treasury shares being canceled [13]</i>	96 790 798			97 174 855	

Subject to the shares held by Cnova within the Reorganization and being cancelled, Casino and its subsidiaries Exito and CBD, as well as the holding company Euris, a French simplified joint-stock with a capital of € 164,806, whose registered office is at 83, rue du Faubourg Saint-Honoré in Paris (75008), registered with the Paris Trade and Companies Register under number 348 847 062 (“**Euris**” which indirectly controls Casino) and Mr. Jean-Charles Naouri (Chairman and CEO of Casino), did not acquire directly or indirectly any share of Cnova during the 12 months preceding the filing of the Offer on December 6, 2016, and had neither entered

into an agreement nor acquired an instrument enabling them to acquire Shares at their sole discretion.

⁹ Exito is a subsidiary of Casino on which Casino has exclusive control. Exito has informed Casino that it will not tender its shares to the Offer and Casino will take the necessary measures to promote its contractual and statutory rights to ensure that Exito will not tender its Shares.

¹⁰ Companhia Brasileira de Distribuicao Netherlands Holding B.V. is a holding company wholly owned by Companhia Brasileira de Distribuicao (CBD), a subsidiary of Casino on which Casino has exclusive control directly and via Exito. CBD has undertaken not to tender its shares to the Offer and Casino will take the necessary measures to promote its contractual and statutory rights to ensure that CBD will not tender its Shares.

¹¹ Being specified that Mr Jean-Charles Naouri controls Casino notably through a company, Euris, that indirectly controls Casino, and has indicated its intention to tender its shares to the Offer.

¹² Of which 122 200 Shares and 25 567 RS.

¹³ 97,174,855 special voting shares and 96,790,798 Distributing Preferred Shares held by Cnova as a result of the Reorganization for the sole purpose of being canceled. This cancellation is expected to take place around January 4, 2017.

*Translation for information purposes only.
In case of discrepancy between the French and the English version, the French version shall prevail.*

The Offer and this draft information memorandum in response remain subject to the review of the AMF

2.2. SHARES GIVING ACCESS TO THE COMPANY'S CAPITAL

The Company has not issued any right, title, capital or financial instrument giving immediate or future access to capital or voting rights, barring:

- the 344,507,048 Shares, of which (i) 308,937,116 held by Casino, Exito, and CBD, which are not targeted by the Offer, (ii) 25,567 RS, which are Shares subject to transfer restrictions until the end of their vesting period and whose allocation to independent directors has been approved by the Board of Cnova on October 30, 2014 under the Cnova NV 2014 Omnibus Incentive Plan. On the RS initially issued, 8,523 have not yet been definitively acquired by their beneficiaries and are theoretically not transferable by the end of the Offer period. Nevertheless, the Offer targets all the RS.
- 1,290,157 DSU issued by the Company and still in effect. They offer a free issuance of a Share by DSU on November 20, 2018. The Offer does not target the DSU as long as they are not transferrable (unless transmission to heirs in case of death of a beneficiary). In addition, 172,389 DSU held by French beneficiaries, under the *Sous Plan Qualifié Français*, could lead, in case of death of a beneficiary, to an anticipated attribution to his heirs of a maximum number of 172,389 Shares, which are targeted by the Offer.

2.3. Statutory restrictions on the exercise of voting rights and share transfers - Agreements known by the company pursuant to article L. 233-11 of the French Commercial Code

Nil.

2.4. Direct and Indirect holdings in the capital of the company

The table in paragraph 2.1.2 reflects the respective shareholdings of the main shareholders of the Company, including Casino and its subsidiaries (Exito and CBD, including Euris which controls indirectly Casino) to date:

- Casino holds 55.4% of the share capital and 57.9% of the voting rights;
- CBD holds 34.5% of the share capital and 35.6% of the voting rights;
- Exito holds 0.19% of the share capital and 0.20% of the voting rights.

Apart from these Casino and CBD, the Company is not aware of shareholders holding individually or in concert at least 3 % of the capital or the voting rights:

2.5. HOLDERS OF SECURITY WITH SPECIAL CONTROL RIGHTS

Subject to the Double Voting Rights Structure described above in section 2.1 of this draft memorandum in response, there are no shareholders with special control rights.

*Translation for information purposes only.
In case of discrepancy between the French and the English version, the French version shall prevail.*

The Offer and this draft information memorandum in response remain subject to the review of the AMF

2.6. CONTROL MECHANISM PROVIDED FOR A POSSIBLE SYSTEM OF EMPLOYMENT SHAREHOLDING WHEN THE CONTROL RIGHTS ARE NOT EXERCISED BY EMPLOYEES

The Company is not aware of any control mechanisms in force to date provided for in possible system of employment shareholding when the control rights are not exercised by employees.

2.7. AGREEMENTS BETWEEN SHAREHOLDERS KNOWN BY THE COMPANY THAT MAY RESULT IN RESTRICTIONS ON TRANSFER OF SHARES OR THE EXERCISE OF VOTING RIGHTS

Apart from what is written above, the Company is not aware of any agreements between shareholders which may result in restrictions on the transfer of shares or the exercise of voting rights.

2.8. RULES APPLICABLE TO THE APPOINTMENT AND REPLACEMENT OF MEMBERS OF THE BOARD OF DIRECTORS AND TO THE AMENDMENT OF THE BYLAWS OF THE COMPANY

The articles of association do not provide for specific rules on the appointment and replacement of directors or on the amendment of the articles of association of the Company that may affect the Offer.

2.9. POWERS OF THE BOARD, ESPECIALLY IN RELATION TO THE ISSUING OR REPURCHASE OF SHARES

The Board of directors holds the following powers, conferred by the general meeting of the shareholders of the Company which took place on June 29, 2016:

Nature of the authorization	Maximum nominal amount authorized	Duration	Date of the shareholders' meeting giving the delegation	Use of the autorisations
Repurchase of shares	A price between zero and an amount not higher to 110% of the average price of the Shares on the NASDAQ or, as the case may be, on Euronext Paris (the average market price being the average of closing market prices on each of the 10 consecutive trading days in the relevant market prior to the second day prior to the date on which the acquisition is agreed by the Company)	18 months starting on the date of the AGM	June 29, 2016	None
Issuance of Shares and special voting rights and granting rights to subscribe for such shares	up to the amount of the authorized capital stipulated in the articles of association from time to time, i.e. the maximum authorization possible (EUR 10 million in the articles of association dated October 31, 2016)	5 years starting on the date of the AGM	June 29, 2016	None
Limit and exclude pre-emption rights in respect of any issue of Shares or any granting of rights to subscribe for such shares	N.A.	5 years starting on the date of the AGM	June 29, 2016	None

The Company has no intention to issue new securities during the offer period.

*Translation for information purposes only.
In case of discrepancy between the French and the English version, the French version shall prevail.*

The Offer and this draft information memorandum in response remain subject to the review of the AMF

2.10. AGREEMENTS SIGNED BY THE COMPANY MODIFIED OR TERMINATED IN CASE OF A CHANGE OF CONTROL

To the knowledge of the Company, there is no significant agreement agreed by Cnova which contains a provision for change of control or any similar provision that could result in termination of such agreement by dint of the Offer. It is stated that the Offer will not result in a change of control which will still be assured by Casino and its subsidiaries.

2.11. AGREEMENTS PROVIDING FOR COMPENSATION OF OFFICERS OR EMPLOYEES, IN CASE OF RESIGNATION, DISMISSAL WITHOUT AN ACTUAL AND SERIOUS CAUSE OR IF THEIR EMPLOYMENT IS TERMINATED DUE TO A PUBLIC TAKEOVER

To the knowledge of the Company, there is no such agreement.

III. Reasoned opinion of the Cnova Transaction Committee

In connection with the Reorganization, Casino has agreed to offer to purchase each outstanding Share in cash for US\$ 5.50 in the US Offer and the equivalent amount in euros in the French Offer at the U.S. Dollar/Euro spot rate taken from the WM/Reuters index at 5:00 p.m on the trading day following the closing date of the Offers and rounded down to the nearest third decimal of euro, it being understood that the global amount to be paid in respect of each tendering order made by a shareholder pursuant to the French Tender Offer will be rounded down to the nearest cent of euro.

The members of the Transaction Committee of Cnova met on 23 November 2016 to discuss the work of Eight Advisory, as independent expert, and the current progress status of the Offer and on December 1st, 2016 for the purpose of discussing Eight Advisory definitive conclusions and examining the proposed Offer.

Before their meeting of December 1st, 2016, members of the Cnova transaction committee received:

- The draft tender offer memorandum prepared by Casino providing for the characteristics of the French Offer, including motives and intents of Casino as well as the elements of determination of the offer price established by J.P. Morgan in its capacity as presenting bank;
- The fairness opinion prepared by Eight Advisory to the Cnova Transaction Committee, dated December 1, 2016, which concludes that as of such date and based upon and subject to the factors, qualifications and assumptions set forth in the fairness opinion and considering the €/U.S. \$ spot rate as of November 23, 2016 of 1.06, the price of USD 5.50 per share offered by the Offeror under the Offer, is, from a financial point of view, fair for the shareholders in Cnova N.V. Furthermore, for information purposes, the fairness opinion states that, in the context of a possible squeeze out procedure governed by Dutch law that may follow the Offer, the price of USD 5.50 per Share and the fairness of this price from a financial standpoint for the minority shareholders in connection with the Offer are important reference points to determine the fair price of a possible squeeze out which would be initiated at the closing of the Offer;
- The draft response memorandum prepared by Cnova;

*Translation for information purposes only.
In case of discrepancy between the French and the English version, the French version shall prevail.*

The Offer and this draft information memorandum in response remain subject to the review of the AMF

The Cnova Transaction Committee also took note that Cnova has neither established a (central or European) works council (*centrale of Europese ondernemingsraad*) nor is in the process of establishing such a works council, and Cnova does not have an obligation to establish a works council pursuant to the mandatory rules of the Works Councils Act (*Wet op de ondernemingsraden*).

Based on the foregoing, the transaction committee, consisting of Messrs. Silvio Genesini, Bernard Oppetit (both independent non-executive directors) and Emmanuel Grenier (executive director and CEO), which is the corporate body competent under Dutch law to provide a reasoned opinion on the Offers and to make a recommendation on the Offers, unanimously adopted the following reasoned opinion which will be fully incorporated into Cnova's response document.

The transaction committee consulted with its legal and financial advisors and considered a number of significant non-financial aspects and potential benefits and advantages associated with the Offers and after deliberation, with the transaction committee considered that:

“Financial conditions

- *The Offer Price of US\$ 5.50 per Share represents:*
 - *a premium of 10% over the price of the Reorganization of USD 5;*
 - *a premium of 23%^[14] over the central value of the range of equity values per Share as set forth in Eight Advisory's report resulting from the discounted cash flow method;*
 - *pursuant to a public trading multiple analysis performed by Eight Advisory that determined a range of equity values per Share, a premium comprised between 15%^[15] and 73%^[16];*
 - *a premium of 88% over the spot rate on March 31, 2016 (the trading day immediately prior to rumors^[17]), a premium of 63% over the spot rate on May 11, 2016 (the day immediately preceding announcement of the financial terms of the reorganization of Cnova and Via Varejo, as well as the Offer) and a premium of 2%^[18] over the spot rate on October 28, 2016,*

¹⁴ Based on values in euros issued from Eight Advisory's report, converted in USD on the basis of the Euro / USD exchange rate on 23 November 2016, i.e. 1.06

¹⁵ Based on the intraday volume-weighted Euronext market price of the Company, converted in USD on the basis of the daily exchange rate

¹⁶ Based on the intraday volume-weighted Euronext market price of the Company, converted in USD on the basis of the daily exchange rate

¹⁷ As set forth in Eight Advisory's report

¹⁸ Based on the intraday volume-weighted Euronext market price of the Company, converted in USD on the basis of the daily exchange rate

*Translation for information purposes only.
In case of discrepancy between the French and the English version, the French version shall prevail.*

The Offer and this draft information memorandum in response remain subject to the review of the AMF

- *The price for the French Offer is determined based on the USD 5.50 price, converted at a spot exchange rate on the day following the closing of the Offer;*
- *The offer price is significantly greater than the economic value of Shares, i.e. US\$ 5.00 per share, determined between Cnova and Via Varejo (in both cases as a result of a negotiation conducted by their respective transaction committees including a majority of independent directors) for the purpose of the Reorganization.*
- *The independent expert appointed by the transaction committee considered that the offer price represents a premium on all valuation criteria it took into account;*
- *Further, taking into consideration the fact that Casino reserves the right to claim for the squeeze out of minority shareholders after the Offers if the conditions are met under Dutch law and that, under Dutch law, the squeeze out price will be determined by the Enterprise Court of Amsterdam and may be, or not, equal to the offer price. The independent expert considered that the Offer price of US\$5.50 per share will be an important reference point to determine the fair price of a possible squeeze out which would be initiated at the closing of the Offer;*
- *There are no significant future synergies resulting from the Reorganization for Cnova, which should be taken into consideration for the valuation of the offer price. However, in the case where, following the Offers, Casino initiates a squeeze out procedure, the Company would be able to make savings in terms of fees relating to the SEC reporting obligations, as well as listing fees and associated advisory costs. The Company estimates that the associated pre-tax cost savings would approximately amount to €4.9 million on a full-year basis;*
- *Taking into consideration the change in the business and financial profile of Cnova resulting from the Reorganization and its focus on the French market, unaffiliated Shareholders will have the possibility elect to tender their Shares in the Offers and thereby receive a cash payment at an attractive premium;*
- *CBD undertook vis-à-vis Casino not to tender its Shares into the Offers, and Exito has indicated that it did not intend to tender its Shares into the Offers;*
- *the agreements between Casino and CBD, regarding notably the future governance of Cnova and the future liquidity of CBD's participation in Cnova, do not grant CBD with any advantage which would be greater than the offer price;*

Operational and employment conditions

- *The Offers will not result in a change of control of Cnova, which is already controlled by Casino;*
- *Casino has indicated to Cnova that it currently has no intention to change the main place of business of Cdiscount in Bordeaux;*

*Translation for information purposes only.
In case of discrepancy between the French and the English version, the French version shall prevail.*

The Offer and this draft information memorandum in response remain subject to the review of the AMF

- *Casino has indicated to Cnova that it believes that a key element of the success of Cnova is preserving and developing the talent and intellectual capital of Cnova's personnel. In this context, Casino does not have any plan to modify Cnova's current strategy regarding staffing.*
- *The terms of the incentive instruments granted to employees under the form of Differed Stock Units (DSU) and Stock Appreciation Rights (SAR) will not be affected by the Offers. If, subsequent to the Offers, Casino decides to squeeze out minority Shareholders and/or to delist the Shares, the Cnova Board of Directors may decide to consider making the adjustments in the terms of the DSU and SAR to take into account these new circumstances, taking into consideration that these instruments do not vest until November 2018.*
- *In connection with the Reorganization the Cnova Board of Directors has decided to amend DSU and SARs which are owned by three employees of Cnova Brazil transferred to the Via Varejo group as a result of the Reorganization, in order for the value of these stock appreciation rights to be indexed, as from the date of execution of the Reorganization Agreement, on the evolution of the stock price of the Via Varejo units. The value of the incentive instruments benefitting to these employees, as adjusted by the transaction committee, was equal to the value of their DSUs and SARs taking into account the stock price of Via Varejo on August 8, 2016, and the agreed value of the Share for the purpose of the Reorganization, i.e. U.S.\$ 5.00 per Share.*

Negative Factors

The Cnova Transaction Committee also considered a variety of risks and other potentially negative factors concerning the Offers, including the following:

- *the management relationship between Cnova and Casino, including the substantial involvement of Casino in Cnova's strategic decision-making processes, including with respect to the Transactions;*
- *the fact that the Offer Price is less than the price at which Shares were initially offered to the public, less than three years prior to the date of this offer to purchase; and*
- *the fact that the exchange of Shares for cash pursuant to either Offer generally will be a taxable transaction for U.S. federal income tax purposes, and may also be a taxable transaction under the laws of other jurisdictions; and*
- *the fact that some Cnova's directors and executive officers may have interests in the Transactions that may be different from, or in addition to, those of the Shareholders; and*
- *the possibility that the closing of the Offers may be delayed for reasons beyond the control of Cnova;*

*Translation for information purposes only.
In case of discrepancy between the French and the English version, the French version shall prevail.*

The Offer and this draft information memorandum in response remain subject to the review of the AMF

Factors Not Considered

In the course of reaching their respective decisions to recommend that Shareholders accept the Offers and tender their Shares into the Offers, the Cnova Transaction Committee and the Cnova Board of Directors, did not consider the liquidation value of Cnova because (i) they considered Cnova to be a viable going concern, (ii) they believe that liquidation sales generally result in proceeds substantially less than sales of going concerns, (iii) they considered determining a liquidation value to be impracticable given the significant execution risk that would be involved in any breakup of Cnova and (iv) Cnova will continue to operate a substantial part of its core eCommerce business following the Transactions. For the foregoing reasons, the Cnova Transaction Committee and the Cnova Board of Directors did not consider liquidation value to be a relevant methodology. Further, the Cnova Transaction Committee and the Cnova Board of Directors did not consider net book value, which is an accounting concept, as a factor because they believed that net book value is not a material indicator of the value of Cnova as a going concern but rather is indicative of historical costs, which will be substantially different from actual costs on a going forward basis at Cnova following completion of the Transactions.

Additionally, the Cnova Transaction Committee and the Cnova Board of Directors did not specifically consider the price to be paid by Casino pursuant to the Offers or the value to be received in the Reorganization by Cnova, on the one hand, as compared to the price paid for purchases of Shares by Casino and its affiliated parties in transactions during the prior two years, on the other hand, because any such transactions were conducted on or before the initial public offering of Cnova, i.e. prior to Cnova's stock price decline reflecting the significant business challenges affecting Cnova Brazil during 2015 and 2016, including poor operating performance and an internal investigation, that lead to a €123 million net loss over the second quarter of 2016.

Further, the Cnova Transaction Committee acknowledged that the following methods have been excluded from Eight Advisory's report:

- *net asset value and adjusted net asset value,*
- *dividend method, and*
- *multiples observed comparable transactions method.*

Financing of the Offers

Casino estimates at approximately US\$195.6 million, the necessary amount to purchase pursuant to the Offers the approximately 35.7 million outstanding Shares that Casino and its affiliates do not already directly or indirectly beneficially own. Casino will finance its purchases pursuant to the Offers with available cash on hand. Consequently, financing for the Offers is not subject to any conditions.

*Translation for information purposes only.
In case of discrepancy between the French and the English version, the French version shall prevail.*

The Offer and this draft information memorandum in response remain subject to the review of the AMF

Procedural safeguards involved in negotiation of the Transactions

The Cnova Transaction Committee also considered a number of factors relating to the procedural safeguards involved in the negotiation of the Transactions, including those discussed below, each of which they believed supported their respective decisions and provided assurance of the fairness of the Transactions to Cnova, unaffiliated Shareholders, and other stakeholders of Cnova:

- *the creation of the Cnova Transaction Committee, which is composed of a majority of directors not affiliated with Casino, CBD or Via Varejo, and the process followed by the Cnova Transaction Committee;*
- *the fact that the Cnova Transaction Committee obtained legal advice regarding the Transactions from Freshfields Bruckhaus Deringer LLP, engaged as the independent legal adviser to the Cnova Transaction Committee;*
- *the fact that, at the time the Transactions were submitted to a vote at Cnova's general meeting of shareholders, allowing all Shareholders to discuss and ask questions about the Transactions before deciding whether to vote in favor of approving the Transactions, such Shareholders were informed of the material terms of the Offers commitment, including the price to be offered pursuant to the Offers;*
- *the fact that the Cnova Transaction Committee took the conclusions of Eight Advisory as an independent expert and received its opinion as fairness of the Offers;*
- *the fact that the Cnova Transaction Committee met numerous times during the course of negotiations with Casino, to review the terms of the proposed Offers;*
- *the fact that, with reference to the Cnova Transaction Committee's decision-making process, the Cnova Transaction Committee has received extensive financial and legal advice both regarding the Reorganization and the Offers;*
- *the fact that the Cnova Transaction Committee, representing the Cnova Board of Directors and consisting of directors unaffiliated with Casino, was aware of the existing relationships among Cnova, Via Varejo and Casino and could take such relationships into account in considering whether to approve the Transactions, including the Offers, and recommend them on the contemplated terms, or at all; and*
- *the unanimous support for the Transactions of all members of the Cnova Transaction Committee."*

*Translation for information purposes only.
In case of discrepancy between the French and the English version, the French version shall prevail.*

The Offer and this draft information memorandum in response remain subject to the review of the AMF

Conclusion

“Based on the foregoing considerations, at its meeting on December 1, 2016, the Cnova Transaction Committee, representing the Cnova Board of Directors, after consultation with its legal and financial advisers, unanimously concluded that it has thoroughly considered the merits, advantages and potential disadvantages, of the Offers and, unanimously (i) concluded that the price to be offered by Casino in the Offers reflects at least full and fair value for the Shares, (ii) determined that the Offers are in the best interest of Cnova, its shareholders and every other stakeholders, (iii) determined that the Offers are fair, advisable and in the interest of the unaffiliated Shareholders and (iv) resolved to fully support the Offers and recommend that Shareholders accept the Offers, and tender their Shares into the Offers.”

The Cnova Transaction Committee’s reasoned opinion is an extract from the shareholder information document “Position Statement” in English, which will be distributed on or about December 22, 2016, and which will be available on the Company’s website (<http://www.cnova.com/en/>), in anticipation of the general meeting of Cnova convened for January 13, 2017, during which information on the Offers will be provided to shareholders.

IV. Intentions of the Board of Directors members

After the completion of the Reorganization, Mr. Estermann, director and President of the Cnova’s Board, also CEO of Via Varejo has resigned from its functions in Cnova. The Cnova’s Board is now composed as follows:

- Antoine Giscard d’Estaing appointed President of the Board on November 17 2016
- Didier Lévêque, Vice Chairman
- Ronaldo Iabrudi dos Santos Pereira, Vice Chairman
- Eleazar de Carvalho Filho
- Silvio J. Genesini
- Bernard Oppetit
- Arnaud Strasser
- Emmanuel Grenier
- Yves Desjacques

Casino and its subsidiary CBD intend to nominate, during the next General Meeting, which will take place on January 13, 2017, a representative of CBD, Mr Christophe José Hidalgo, as a board member, in accordance with the Casino-CBD Commitment Letter, so that the commitments under this letter in terms of governance are respected. On the occasion of this general meeting, Mr Didier Lévêque will resign from his functions as board member.

*Translation for information purposes only.
In case of discrepancy between the French and the English version, the French version shall prevail.*

The Offer and this draft information memorandum in response remain subject to the review of the AMF

The following Cnova board members hold Shares or RS in the quantities detailed in the table below:

Board members	Shares	RS	
		Number of RS vested before the Offer period	Number of RS which will be vested after the Offer period
Bernard Oppetit	120,000	5,714	2,857
Silvio Genesini	n/a	5,665	2,833
Eleazar de Carvalho Filho	n/a	5,665	2,833
Antoine Giscard d'Estaing	2,200	n/a	n/a

These members have expressed their intention to tender their Shares and / or RS, as the case may be, to the Offer.

*Translation for information purposes only.
In case of discrepancy between the French and the English version, the French version shall prevail.*

The Offer and this draft information memorandum in response remain subject to the review of the AMF

V. Report of the independent expert

*Translation for information purposes only.
In case of discrepancy between the French and the English version, the French version shall prevail.*

The Offer and this draft information memorandum in response remain subject to the review of the AMF

VI. Modalities for making available the information relating to the company

The information relating in particular to the legal, financial and accounting characteristics of Cnova N.V. will be filed with the AMF and made available to the public no later than on the day preceding the opening of the tender offer. Pursuant to Article 231-28 of the General Regulation, they will be available on the Cnova (<http://www.cnova.com/en/>) and AMF (www.amf-france.org) websites, the day before the opening of the Offer and may be obtained free of charge from Cnova NV - Schiphol Boulevard 273, 1118 BH Schiphol, Netherlands.

*Translation for information purposes only.
In case of discrepancy between the French and the English version, the French version shall prevail.*

The Offer and this draft information memorandum in response remain subject to the review of the AMF

VII. Persons responsible for the draft information memorandum in response

« To our knowledge, the information in the draft information memorandum in response is complete and accurate and does not contain any omission likely to alter its scope. »

[●] 2016

CNOVA N.V.
Represented by its Chief
Executive Officer